



**EQUIPAMIENTOS
TECNICOS
COMERCIALES, S.A.**

**DIRECCION POSTAL
POSTAL ADDRESS**

Apartado 1.066 / P.O. Box 1.066
48080 BILBAO - SPAIN

**FABRICA Y OFICINAS
FACTORY AND OFFICES**

San Martín, 11
48170 ZAMUDIO - SPAIN
Teléfono / Phone: (34) 94 452 09 61
Fax / Fax: (34) 94 452 07 03

**REDUCTORES
DE VELOCIDAD**

**SPEED GEAR
UNITS**

TIPOS TANDEM TYPES

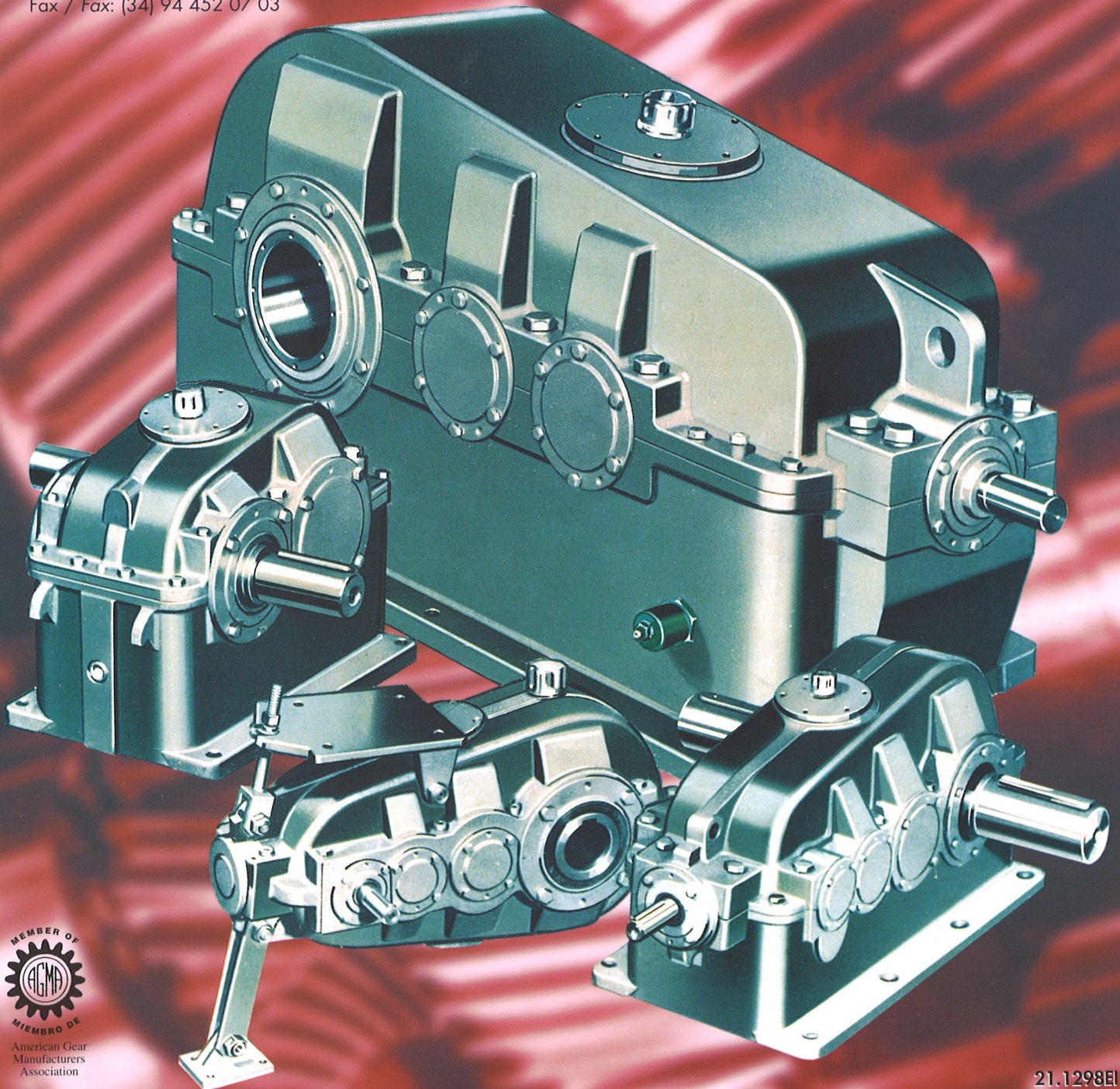

American Gear
Manufacturers
Association

INDICE / INDEX



PRESENTACION
PRESENTATION



GENERALIDADES
GENERALITIES



INDICE INFOGRAFICO
INFOGRAPHIC INDEX



GRUPOS DE CARGA SEGUN MAQUINA RECEPTORA
LOAD CLASSIFICATION OF DRIVEN MACHINES



FACTORES DE APLICACION
APPLICATION FACTORS



EJEMPLOS DE SELECCION
SELECTION EXAMPLES



REDUCTORES EJES PARALELOS
PARALLEL SHAFTS



REDUCTORES EJES PERPENDICULARES
PERPENDICULAR SHAFTS



ARBOL HUECO - TRANSMISION POR CHAVETA
HOLLOW SHAFT - KEY DRIVE



ARBOL HUECO - TRANSMISION POR ELEMENTOS DE APRIETE
HOLLOW SHAFT - TIGHTENING ELEMENT DRIVE



PUNTOS DE CENTRADO CHAVETAS Y CHAVETEROS
CENTERING POINTS KEYS AND KEYWAYS



SIMBOLOS Y UNIDADES DE MEDIDA
SYMBOLS AND UNITS OF MEASURE



FORMULARIO
COLLECTION OF FORMULAS



FICHA DE DATOS
DATA CARD

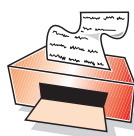
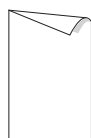
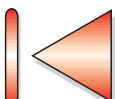
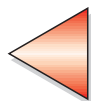
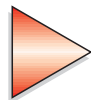

PRESENTACION

DEPARTAMENTO DE PROYECTOS

Dotado de moderno equipamiento para el diseño y un equipo humano altamente cualificado, nuestro Departamento de Proyectos en sus diversas secciones, le brindará la solución idónea a cualquier problema de transmisión de velocidad y/o potencia, desde el reductor más simple al conjunto tecnológicamente más complejo.

La Ingeniería ofrece a la empresa industrial en los diversos sectores, Siderúrgico, Petroquímico, Obras Públicas, Minero, Energético, Bienes de Equipo, etc., las soluciones técnicas más avanzadas.

La Oficina Técnica, junto con la unidad de CAE/CAD/CAM y la sección de Métodos, desarrolla y proyecta conforme a las más modernas tecnologías y la última normativa internacional, optimizando el diseño de componentes y conjuntos a través del análisis y la simulación del comportamiento mecánico, térmico, etc. de los mismos.

DEPARTAMENTO DE FABRICACION

Sus diferentes secciones de mecanización, montaje, almacenamiento y acabado, ocupan una superficie de 3.000 m.2

Las secciones de mecanización disponen de máquinas-herramientas universales y especiales, dotadas de equipos C.N.C. e instalaciones especializadas de gran capacidad, mecanizándose por estos modernos procedimientos el 70% de nuestros componentes.

Todos los procedimientos de fabricación están desarrollados conforme a las normas nacionales e internacionales y homologados por las empresas más importantes.

Los procesos de fabricación son controlados por procedimientos informáticos, asegurando el control y cumplimiento de todas las fases y especificaciones.

DEPARTAMENTO DE GARANTIA DE CALIDAD

A través de sus secciones y aplicando rigurosos procedimientos homologados, se controla la calidad de los diferentes materiales y de los diversos procesos industriales.

En el laboratorio metalográfico, se analizan los componentes y estructuras de los materiales y sus tratamientos. La sección de verificación, con el empleo de modernos equipos, realiza a los diversos elementos incorporables, controles dimensionales, de rigurosidad, dureza, etc. y ensayos no destructivos mediante equipos de ultrasonidos, corrientes electromagnéticas, etc.

Los productos terminados son sometidos a diversas pruebas y ensayos, evaluando su rendimiento y comportamiento mediante el control de parámetros de evolución térmica, ruidos, vibraciones, etc., quedando registrados los resultados para su seguimiento posterior.

SUS APLICACIONES Y NUESTRA VOLUNTAD

Nuestros productos son normalmente utilizados por todos los sectores de actividad industrial.

Sector Siderúrgico, Sector de Obras Públicas y Minería, Sector Químico y Petroquímico, Sector Hidroeléctrico, Plantas Cementeras, Papeleras, Azucareras, ..., Depuradoras. Instalaciones de Manipulación y Transporte de graneles. Energías alternativas y renovables, ..., etc.

Estamos presentes en cualquier actividad humana relacionada con la producción, transmitiendo siempre potencia.

Le ofrecemos a través de nuestra red comercial, nuestra experiencia, avalada por más de 35 años dedicados al mundo de las transmisiones y el conocimiento y dominio de las últimas tecnologías.

Confíe en nuestros expertos que, con seguridad, le brindarán soluciones idóneas para sus problemas específicos.

PRESENTATION

PROJETS DEPARTMENT

Provided with modern desing equipment and a highly qualified staff, the various sections of our Projets Department offer you the ideal solution to whatever problem you may have transmitting speed and / or power from the most basic gear unit, to the most technologically complex unit.

The engineering office offers the most advanced technical solutions for industrial companies in fields as diverse as the Iron and Steel industry, Petrochemical, Public Works, Mining, Energy, Capital Goods, etc.

The technical office, together with the CAE / CAD / CAM unit and the method section, designs and develops products using the most up-to-date technology, and in line with the latest international standards, optimizing the desing of components and assemblies by means of the analysis and simulation of their mechanical , thermic, etc, behaviour.

MANUFACTURING DEPARTMENT

Its various sections of mechanizing, assembly, storage and finishing occupy an area of 3.000 m2.

The mechanizing sections have at their disposal universal and specific machine tools provided with C.N.C. equipment and high-capacity specialized installations: 70% of our components are mechanized by means of these modern procedures.

All manufacturing procedures are developed according to national and international standards approved by the most important companies.

The manufacturig processes are controlled by computerized procedures, insuring the control and fullfilment of all the phases and specifications.

QUALITY CONTROL DEPARTMENT

The quality of the different materials, as well as the diverse industrial processes, are controlled by means of its sections and employing strict homologated procedures.

In the metallographic laboratory, the analysis of the components and structures of the materials and their treatments is carried out.

The checking section, using modern equipment, realizes to the several elements to be incorporated controls of size, rugosity, hardness, and non-destructive test by means of ultrasonic equipment, electromagnetic currents, etc.

The finished units are exposed to various test and trials, evaluating their efficiency and behavior by means of the control of thermic evolution parameters, noises, vibrations, etc. These results are recorded for subsequent follow-up.

YOUR APPLICATIONS AND OUR WILL

Our products are normally used in all sectors of industrial activity.

The iron and steel sector, the Public Work and Mining sector, the Chemical and petrochemical sector, the Hydroelectric sector, Cement, Paper and Sugar plants..., Purifying plants. Installations for Handling and Transport of bulks. Alternative and Renewable energy sources, etc.

We are present at every human activity related to production, always transmitting power.

Via our commercial network we offer you our experience, with the guarantee of over 35 years dedicated to the world of transmission and to the knowledge and command of today's technology.

Trust in our experts to offer you the ideal tailor-made solution for your problem.

INTRODUCCION

Les presentamos el nuevo catálogo de los ya introducidos y experimentados reductores tipo TANDEM de nuestra gama de fabricación. El mismo se ve incrementado por nuevos tamaños y formas constructivas de reductores así como en potencias transmisibles.

Las características de intercambiabilidad y construcción de los reductores son las mismas que se vienen aplicando en los últimos tiempos y que son las que rigen actualmente en la UE. Esto es: NORMALIZACION de medidas principales como son distancias entre árboles, altura de éstos respecto a la base, diámetros de los mismos y la construcción de engranes en aceros de CEMENTACION con los flancos de los dientes rectificadas. De hecho, los grandes constructores de reductores vienen aplicando, desde hace tiempo, esta tecnología. Habiéndose conseguido una absoluta fiabilidad en la calidad de los tratamientos, la cementación ofrece una dureza superficial idónea, con una gran resistencia en el núcleo sin debilitar el material, dado el reducido espesor de la capa cementada.

Las pequeñas deformaciones que puedan producirse, sobre todo en engranajes de gran diámetro, se corrigen en el rectificado posterior de los flancos del dentado.

Con todo ello se reduce mucho el tamaño y peso de los reductores así contruidos, sin perjudicar su duración ni su capacidad de absorción de sobrecargas.

MATERIALES Y CARACTERISTICAS CONSTRUCTIVAS

CARCASAS

Son construidas en fundición gris de alta calidad o en acero electro-soldado y distensionado. Su estanqueidad es perfecta y escrupulosamente comprobada. Su superficie de unión coincide con el plano de los ejes, facilitando así el montaje. Disponen de ventana de inspección, tapón de vaciado en el punto más bajo, válvula de aireación en evitación de sobrepresiones y varilla de nivel. Todo ello en el caso más simple.

ENGRANAJES

Construidos en aceros de cementación. Tratados térmicamente por cementación, temple y revenido. Consiguiéndose durezas superficiales de 58° a 60° HRc en las ruedas y de 59° a 61° HRc en los piñones. Con flancos de dentado rectificadas.

En los reductores de árboles paralelos son cilíndrico-helicoidales. Las inclinaciones tienden a compensar los esfuerzos axiales. Los reductores de árboles perpendiculares llevan un primer tren de dentado cónico-espiral tallado y lapeado con sistema GLEASON y los restantes cilíndrico-helicoidales.

ARBOLES LENTOS

Para los árboles lentos se utilizan aceros al carbono y aceros de alta resistencia.

Pueden ser macizos o huecos y éstos últimos previstos para arrastre por chaveta o por elementos de apriete.

RODAMIENTOS

Se presta especial atención al minucioso cálculo de las cargas que puedan sufrir los rodamientos, tanto las internas como las debidas a agentes exteriores (correas, cadenas, etc.), con el fin de adecuar perfectamente el tipo de rodamientos al trabajo que debe realizar, asegurando una duración no inferior a la de los engranes.

MECANISMOS DE ANTI-RETORNO

Todos los reductores pueden ser equipados con uno de estos mecanismos que impiden el giro en uno de los dos sentidos.

ENGRASE

Puede ser por barboteo o a presión, en los casos en que sea necesario. Este último puede realizarse mediante moto-bomba o con una bomba autónoma comandada por uno de los árboles del reductor.

REFRIGERACION

El alto rendimiento de los engranajes de dientes rectificadas disminuye sensiblemente el calor a evacuar, por lo que en la mayoría de los casos es suficiente la refrigeración natural a través de las paredes de las carcasas. No obstante, para grandes potencias, pueden utilizarse enfriadores de aceite interiores o exteriores al reductor y también sistemas de engrase centralizado que proporcionan al lubricante la temperatura adecuada.

Los sistemas de engrase a presión, con o sin refrigeración, pueden estar dotados de elementos de control (manómetros, presostatos, termómetros, caudalímetros) en combinación, ocasionalmente, con aparatos de alarma ópticos o acústicos.

INTRODUCTION

We present you the new catalogue of the already introduced and experienced TANDEM type gear units of our range of production. It has been increased in new sizes and types of construction of the gear units, as well as in transmissible powers.

The characteristics of interchangeability and construction of the gear unit are the same ones that have been applying lately, and that at the moment govern in the EU That is: STANDARDIZATION of main dimensions, such as distance between shafts, height of these ones in relation to the base, their diameters,..., and the manufacture of the gears of CASEHARDENED STEEL with the teeth side grinded. In fact, the great manufacturers of gear units have been applying this technology for a long time. Having obtained an absolute reliability on the quality of the treatment, carburizing offers a suitable surface hardness, with a great internal strength without weaken the material, due to the reduced thickness of the carburized layer.

The small deformations that can take place, specially in big size gears, are corrected during the later grinding of the teeth side.

Because of this, the size and weight of the gear units manufactured in this way are reduced, without damaging their life or their extra load supporting capacity.

MATERIALS AND CONSTRUCTIVE CHARACTERISTICS

HOUSINGS

Housings are made of high quality grey cast iron or of electrowelded and stress relieved steel. Their tightness is perfect and scrupulously checked. Their union surface coincides with the axis plane, making easy the mounting. They have inspection window, drain plug at the lower point, aeration plug to avoid over-pressure and oil level stick. All these elements are included in the simplest case.

GEARS

Gears are made of casehardened steel. They are heat treated (carburizing, hardening and tempering), obtaining a surface hardness of 58° to 60° HRC at the wheels, and of 59° to 61° HRC at the pinions. Gears have their teeth sides grinded.

In parallel shafts gear units, gears are helical. Their lead angles tend to balance the thrust loads. Perpendicular shafts gear units have the first gear train bevel, engraved and lapped with GLEASON system, and the other gears helical.

SLOW SHAFTS

For slow shafts, carbon steel and high strength steel is used.

They can be solid or hollow, and the hollow ones are planned for keying or for tightening elements.

BEARINGS

A special attention is paid to the through calculus of the loads that the bearing have to stand, both the internal loads and those owing to external agents, (belts, chains, etc.), with the purpose of fitting the bearing for the type of work they have to achieve, to guarantee a lifetime non-inferior to the gears one.

BACKSTOP MECHANISMS

The gear units can be equipped with one of these mechanisms, that prevent the shafts rotation in one of the two directions.

LUBRICATION

It can be by splash or forced feed, if it is necessary. The forced feed lubrication can be carried out by a pump and engine or by a pump driven by one of the shafts of the gear unit.

COOLING

The high efficiency of grinded teeth gears decreases appreciably the heat to dissipate, so in most cases the natural cooling trough the surface of the housing is enough. However, for great power gear units, internal or external oil coolers can be used, as well as lubricating stations which keep an adequate oil temperature.

Forced feed lubrication systems, with or without cooling, can be equipped with controls (manometers, pressure switches, thermometers, flowmeters) and sometimes together with optic or sonic warning devices.

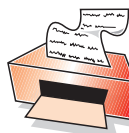
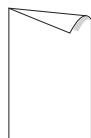
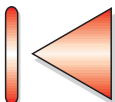
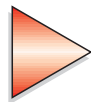

REDUCTORES TANDEM

INDICE INFOGRAFICO

TANDEM GEAR UNITS

INFOGRAPHIC INDEX

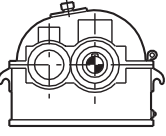
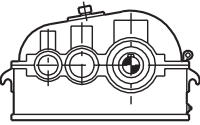
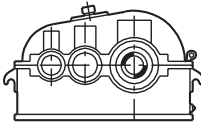
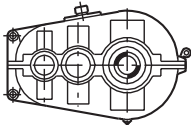
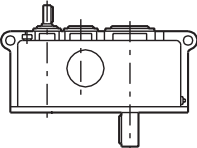
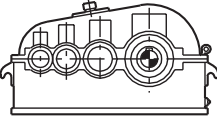
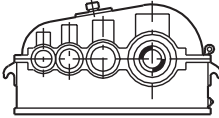
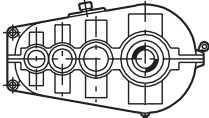
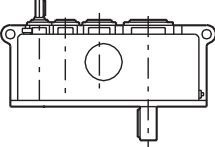
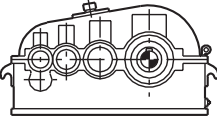
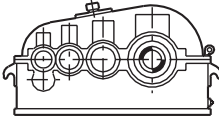
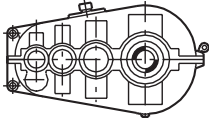
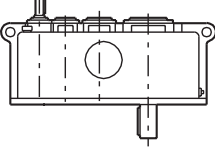

• Ejemplos de Fabricación / <i>Manufacture examples</i>	Pág. -
• Presentación / <i>Presentation</i>	Pág. 1
• Generalidades / <i>Generalities</i>	Pág. 2-3
• Índice Infográfico / <i>Infographic Index</i>	Pág. 4
• Grupos de carga / <i>Load classification</i>	Pág. 5
• Factores de Aplicación / <i>Application factors</i>	Pág. 6
• Ejemplos de Selección / <i>Selection examples</i>	Pág. 7

 <p>Tipo TS Type</p>				<p>Un tren de engranajes cilíndrico helicoidales Ejes paralelos</p> <hr/> <p><i>Single stage helical gear unit. Parallel shafts.</i></p> <p>Pág. 8</p>
 <p>Tipo TD Type</p>	 <p>Tipo TDA Type</p>	 <p>Tipo PDA Type</p>	 <p>Tipo TDPV Type</p>	<p>Dos trenes de engranajes cilíndrico helicoidales Ejes paralelos</p> <hr/> <p><i>Two stage helical gear unit. Parallel shafts.</i></p> <p>Pág. 10</p>
 <p>Tipo TT Type</p>	 <p>Tipo TTA Type</p>	 <p>Tipo PTA Type</p>	 <p>Tipo TTPV Type</p>	<p>Tres trenes de engranajes cilíndrico helicoidales Ejes paralelos</p> <hr/> <p><i>Three stage helical gear unit. Parallel shafts.</i></p> <p>Pág. 15</p>
 <p>Tipo TC Type</p>	 <p>Tipo TCA Type</p>	 <p>Tipo PCA Type</p>	 <p>Tipo TCPV Type</p>	<p>Cuatro trenes de engranajes cilíndrico helicoidales Ejes paralelos</p> <hr/> <p><i>Four stage helical gear unit. Parallel shafts.</i></p> <p>Pág. 20</p>

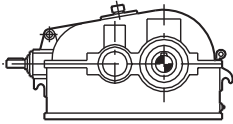
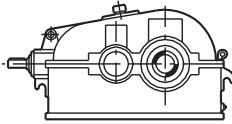
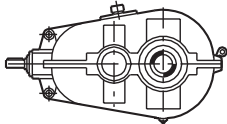
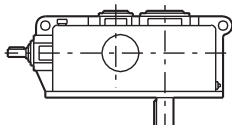
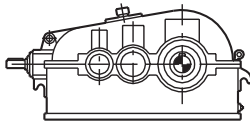
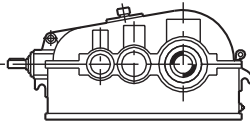
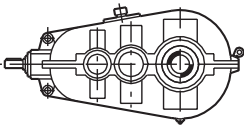
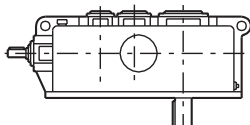
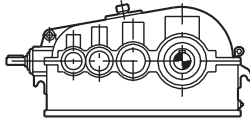
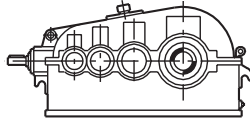
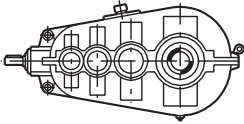
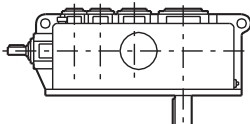
 <p>Tipo TDH Type</p>	 <p>Tipo TDHA Type</p>	 <p>Tipo PDHA Type</p>	 <p>Tipo TDHV Type</p>	<p>Dos trenes de engranajes cónico y cilíndrico helicoidales Ejes perpendiculares</p> <hr/> <p><i>Two stage bevel helical gear unit. Perpendicular shafts.</i></p> <p>Pág. 25</p>
 <p>Tipo TTH Type</p>	 <p>Tipo TTHA Type</p>	 <p>Tipo PTHA Type</p>	 <p>Tipo TTHV Type</p>	<p>Tres trenes de engranajes cónico y cilíndrico helicoidales Ejes perpendiculares</p> <hr/> <p><i>Three stage bevel helical gear unit. Perpendicular shafts.</i></p> <p>Pág. 30</p>
 <p>Tipo TCH Type</p>	 <p>Tipo TCHA Type</p>	 <p>Tipo PCHA Type</p>	 <p>Tipo TCHV Type</p>	<p>Cuatro trenes de engranajes cónico y cilíndrico helicoidales Ejes perpendiculares</p> <hr/> <p><i>Four stage bevel helical gear unit. Perpendicular shafts.</i></p> <p>Pág. 35</p>

• Arbol Hueco / <i>Hollow shaft</i>	Pág. 40
• Puntos de centrado, chavetas y chaveteros / <i>Centering points, keys and keyways</i>	Pág. 41
• Símbolos y Unidades de medida / <i>Symbols and units of measure</i>	Pág. 42
• Formulario / <i>Collection of formulas</i>	Pág. 43
• Ficha de datos / <i>Data card</i>	Pág. 44
• Derivados Tandem y Especiales / <i>Tandem derived and special gear units</i>	Pág. 45

Equipamientos Técnicos Comerciales, S.A. se reserva el derecho de realizar cualquier modificación. / Equipamientos Técnicos Comerciales, S.A. reserves the right to modification.

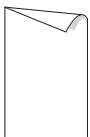
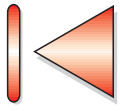

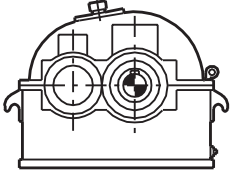
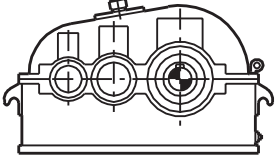
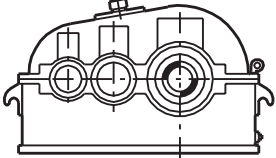
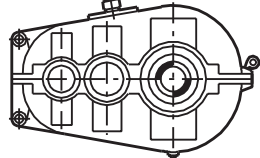
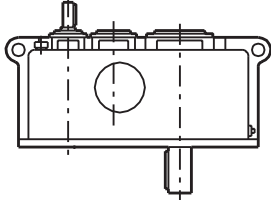
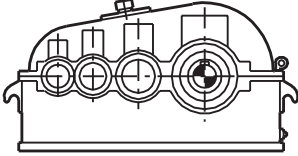
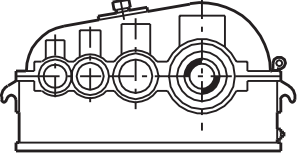
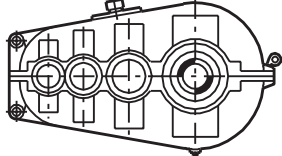
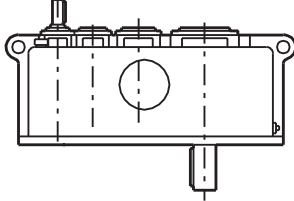
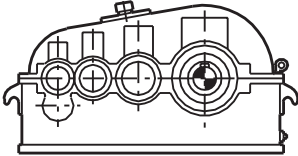
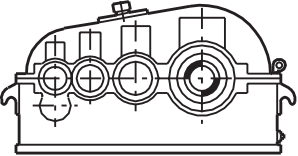
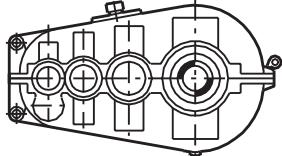
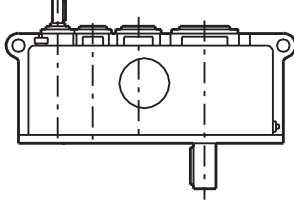
 <p>Tipo TS Type</p>	<p>Un tren de engranajes cilíndrico helicoidales Ejes paralelos</p> <hr/> <p><i>Single stage helical gear unit. Parallel shafts.</i></p> <p>Pág. 8</p>
    <p>Tipo TD Type Tipo TDA Type Tipo PDA Type Tipo TDPV Type</p>	<p>Dos trenes de engranajes cilíndrico helicoidales Ejes paralelos</p> <hr/> <p><i>Two stage helical gear unit. Parallel shafts.</i></p> <p>Pág. 10</p>
    <p>Tipo TT Type Tipo TTA Type Tipo PTA Type Tipo TTPV Type</p>	<p>Tres trenes de engranajes cilíndrico helicoidales Ejes paralelos</p> <hr/> <p><i>Three stage helical gear unit. Parallel shafts.</i></p> <p>Pág. 15</p>
    <p>Tipo TC Type Tipo TCA Type Tipo PCA Type Tipo TCPV Type</p>	<p>Cuatro trenes de engranajes cilíndrico helicoidales Ejes paralelos</p> <hr/> <p><i>Four stage helical gear unit. Parallel shafts.</i></p> <p>Pág. 20</p>

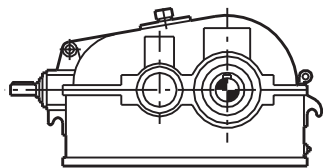

Tipo **TDH** Type

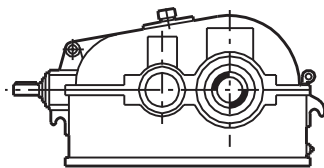

Tipo **TDHA** Type

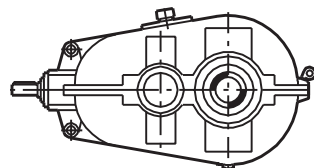

Tipo **PDHA** Type

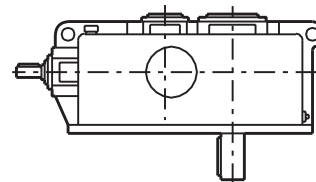

Tipo **TDHV** Type

Dos trenes de engranajes cónico y cilíndrico helicoidales
Ejes perpendiculares

*Two stage bevel
helical gear unit.
Perpendicular shafts.*

Pág. 25

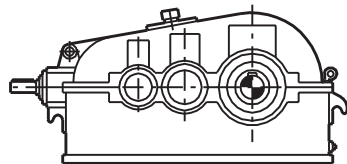

Tipo **TTH** Type

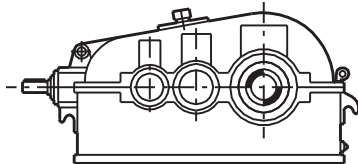

Tipo **TTHA** Type

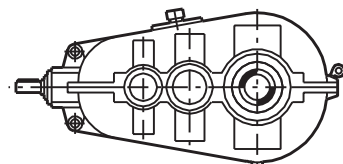

Tipo **PTHA** Type

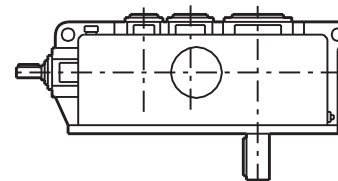

Tipo **TTHV** Type

Tres trenes de engranajes cónico y cilíndrico helicoidales
Ejes perpendiculares

*Three stage bevel
helical gear unit.
Perpendicular shafts.*

Pág. 30

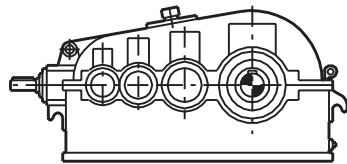

Tipo **TCH** Type

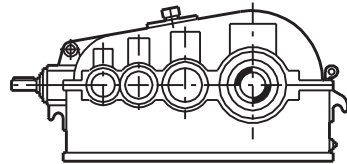

Tipo **TCHA** Type

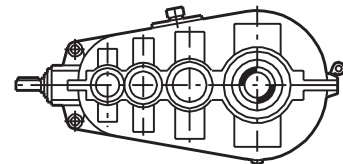

Tipo **PCHA** Type

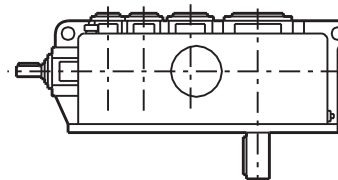

Tipo **TCHV** Type

Cuatro trenes de engranajes cónico y cilíndrico helicoidales
Ejes perpendiculares

*Four stage bevel
helical gear unit.
Perpendicular shafts.*

Pág. 35

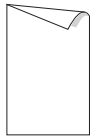
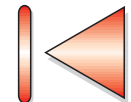

REDUCTORES TANDEM

GRUPOS DE CARGA
SEGUN MAQUINA RECEPTORA

TANDEM GEAR UNITS

LOAD CLASSIFICATION
OF DRIVEN MACHINES



MAQUINA RECEPTORA	GRUPOS DE CARGA	DRIVEN MACHINE
CARGA UNIFORME, PEQUEÑAS MASAS A ACELERAR.	LOAD CLASSIF.	UNIFORM LOAD, LIGHT MASSES TO ACELERATE
<p>Generadores eléctricos. Transportadores ligeros (elevadores, cintas, tornillo sin-fin, etc.) Soplantes, Turbo-soplantes y Turbo-compresores. Agitadores y mezcladores para líquidos homogéneos. Bombas centrífugas para materiales líquidos. Escaleras mecánicas. Máquina Herramienta (accionamientos auxiliares). Maquinaria para transformación de madera. Gruas: Cabrestantes, mecanismos de arrastre. Maquinaria industria alimenticia: Embaladoras, embotelladoras.</p>	I	<p>Electric generators. Light conveyors (elevators, belts, screws, etc). Blowers, Turbo-blowers and Turbo-compressors. Agitators and mixers for homogeneous liquids. Centrifugal pumps for liquid materials. Movig ladders. Machine tool. (Auxiliar drives). Wood processing machines. Cranes, Winches, luffing gears. Food industry machinery: Packaging machines, fillers.</p>
CARGA NO UNIFORME, MASAS MEDIANAS Y GRANDES A ACELERAR. MEDIANOS CHOQUES.		NO UNIFORM LOAD, MEDIUM AND HEAVY MASSES TO ACELERATE. MODERATE SHOCKS
<p>Agitadores y mezcladores para productos no homogéneos. Gruas: Mecanismos basculantes, elevación, orientación. Transportadores pesados (elevadores, cintas, cangilones, etc.) Soplantes rotativos. Ventiladores-torres de refrigeración, de tiro forzado. Bombas a pistones múltiples, de distribución, centrífugas o de tornillo. Mezcladores de hormigón. Compresores de émbolo con volante de impulsión. Laminadores continuos y caminos de rodillos ligeros. Trituradores y molinos para la industria alimenticia. Hornos y secadores giratorios. Vibradoras. Instalaciones de lavado: Máquinas de lavar, tambores secadores. Maquinaria textil y similar. Extrusoras medias para plástico y caucho. Espesadores medios. Montacargas ligero.</p>	II	<p>Agitators and mixers for non-homogeneous materials. Cranes: Tipping gears, hoist gears, slewing gears. Heavy conveyors. (Elevators, belts, buckets, etc). Rotary blowers. Ventilators for cooling towers. Multiple pistons pumps, distribution, centrifugal or screw. Concrete mixers. Reciprocating compressors with impulsion wheel. Continuous mills and light roller tables. Crushers and mills for food industry. Rotary furnaces and dryers. Vibrators. Washing plants: Washing machines, drying cylinders. Textile machinery and similar. Rubber and plastic medium extruders. Medium thickeners. Light elevators.</p>
CARGA NO UNIFORME, MASAS GRANDES A ACELERAR. FUERTES CHOQUES.		NO UNIFORM LOAD, HEAVY MASSES TO ACELERATE. HEAVY SHOCKS
<p>Prensas de embutido y forjado. Martillos. Cizallas. Transportadores de lingote. Extrusoras pesadas. Trenes de laminación: Chapa fina y gruesa. Trenes de laminación en frío. Trenes desbastadores de palanquilla. Caminos de rodillos pesados. Amasadoras y laminadoras de goma, calandras, etc. Gruas: Mecanismos de traslación. Palas mecánicas, excavadoras, machacadoras, trituradoras, etc. Centrifugadores pesados. Grandes bombas de émbolo. Volcadores siderúrgicos. Molinos de percusión, de martillos de barras y de bolas. Grandes compresores de émbolo sin volante de inercia. Punzonadoras. Descortezadoras. Montacargas pesados.</p>	III	<p>Dishing and forging presses. Hammers. Shears. Ingot conveyors. Heavy extruders. Sheet and Plate mills. Cold rolling mills. Ingot slab mills. Heavy roller tables. Rubber kneading machines, mills, calenders, etc. Cranes: Travelling gears. Shovels. excavators, crushers, etc. Heavy centrifuges. Big reciprocating pumps. Foundry tilters. Impact mills, rod mills, ball mills. Big reciprocating compressors without impulsion wheel. Stamping machines. Debarking machines. Heavy elevators.</p>

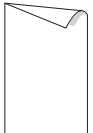
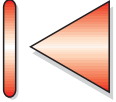

FACTORES PARA ESTABLECER
LA POTENCIA NOMINAL P_{Nn}

FACTORS TO DETERMINATE
THE NOMINAL POWER P_{Nn}

FACTOR DE APLICACION f_1
APPLICATION FACTOR f_1

Máquina motriz Driving machine	Grupo de carga Load classification	Horas de funcionamiento diarias / Service hours per day		
		Hasta 3 Under 3	De 3 a 10 3 to 10	De 10 a 24 10 to 24
Motor eléctrico - Turbina de vapor. Electric motor - Steam turbine.	I	0,8	1	1,25
	II	1	1,25	1,5
	III	1,5	1,75	2
Motores de combustión interna de cilindros múltiples (4-6). Turbina de agua. Multi-cylinder combustion engine (4-6). Water turbine	I	1	1,25	1,5
	II	1,25	1,5	1,75
	III	1,75	2	2,25
Motores de combustión interna con 1-3 cilindros. 1-3 cylinders combustion engine.	I	1,25	1,5	1,75
	II	1,5	1,75	2
	III	2	2,25	2,5

FACTOR DE APLICACION f_2
APPLICATION FACTOR f_2

Arranques hora Z Starts per hour Z	Grupos de carga / Load classification		
	I	II	III
1	1	1	1
2 a 20	1,15	1,08	1,07
21 a 40	1,25	1,17	1,12
41 a 80	1,45	1,25	1,15
81 a 160	1,55	1,35	1,16
> 160	1,9	1,65	1,25

FACTOR DE APLICACION f_3
APPLICATION FACTOR f_3

Horas de vida Lifetime	f_3
5.000	0,85
12.500	0,93
25.000	1
50.000	1,07
75.000	1,11
100.000	1,14

FACTORES PARA ESTABLECER
LA POTENCIA LIMITE TERMICA P_{Gn}

FACTORS TO DETERMINATE THE
MAXIMUM THERMAL POWER P_{Gn}

FACTOR TERMICO f_t
THERMAL FACTOR f_t

Duración de conexión ED % Running time ED %	Sin refrigeración / Without cooling					Refrigeración por ventilador o serpentín Fan or coil cooling				
	Temperatura ambiente °C / Ambient temperature °C					Temperatura ambiente °C / Ambient temperature °C				
	10	20	30	40	50	10	20	30	40	50
100	1,12	1	0,88	0,75	0,63	1,12	1	0,9	0,8	0,7
80	1,35	1,2	1,05	0,9	0,75	1,35	1,2	1,08	0,96	0,84
60	1,6	1,4	1,25	1,05	0,9	1,6	1,4	1,25	1,13	0,97
40	1,8	1,6	1,4	1,2	1	1,8	1,6	1,45	1,28	1,12
20	2,05	1,8	1,6	1,35	1,15	2	1,8	1,5	1,44	1,26

FACTOR DE APLICACION TOTAL f_a
TOTAL APPLICATION FACTOR f_a

$$f_a = f_1 \cdot f_2 \cdot f_3$$

Equipamientos Técnicos Comerciales, S.A. se reserva el derecho de realizar cualquier modificación. / Equipamientos Técnicos Comerciales, S.A. reserves the right to modification.

EJEMPLO 1

Desearnos seleccionar un mecanismo de las siguientes características:

Mecanismo:	Reductor de velocidad
Posición de ejes:	Paralelos
Máquina receptora:	Turbo-compresor
Máquina motriz:	Motor eléctrico
Potencia nominal motor:	$P_1 = 315 \text{ Kw}$.
Potencia absorbida por la máquina receptora:	$P_a = 256 \text{ Kw}$.
Velocidad nominal del motor:	$n_1 = 1.500 \text{ r.p.m.}$
Velocidad nominal de la máquina receptora:	$n_2 = 536 \text{ r.p.m.}$
Relación de transmisión:	$n_1/n_2 = i_N = 2,8$
Horas de funcionamiento diarias:	24
Cantidad de arranques por hora:	15
Duración de conexión ED:	100 %
Temperatura ambiente:	30° C
Horas de vida:	50.000

Seguimiento para establecer el tipo y tamaño

- Determinación del factor de aplicación f_a .

Grupo de carga (pág. 5): I
 Factor f_1, f_2 y f_3 (pág: 6): $f_1 = 1,25; f_2 = 1,15; f_3 = 1,07$
 $f_a = f_1 \cdot f_2 \cdot f_3 = 1,25 \cdot 1,15 \cdot 1,07 = 1,54$

- Potencia nominal necesaria P_{Nn}

$$P_{Nn} = P_a \cdot f_a = 256 \cdot 1,54 = 394 \text{ Kw.}$$

Nota: Si se desconoce la potencia absorbida, realizar la fórmula con la potencia motor P_1 .

- Tipo y tamaño

Por posición de ejes y relación de transmisión, pasamos a la pág. 8. Tipo TS.

Con la relación i_N , velocidad n_1 y Potencia Nominal necesaria P_{Nn} , establecemos con la condición $P_n \geq P_{Nn}$, el tamaño 200, con $P_n = 395 \text{ Kw} > P_{Nn}$.

SELECCION: TS-200

Seguimiento para establecer el sistema de refrigeración

- Determinación del factor térmico f_t en pág. 6.

- **1ª comprobación: sin refrigeración.**
 $f_t = 0,88$

Potencia límite térmica necesaria P_{Gn} .

$$P_{Gn} = P_{G1} \cdot f_t = 146 \cdot 0,88 = 128 \text{ Kw.}$$

P_{G1}, P_{G2}, P_{G3} en pág: 8.

Válido si $P_a \leq P_{Gn}$.

Como $P_a > P_{Gn}$, no es válido sin refrigeración.

- **2ª comprobación: Refrigeración por ventilador**

Factor térmico $f_t = 0,9$

$$P_{Gn} = P_{G2} \cdot f_t = 260 \cdot 0,9 = 234 \text{ Kw.}$$

Como $P_a > P_{Gn}$ no es válido con ventilador.

- **3ª Comprobación: Refrigeración por serpentín.**

Factor térmico $f_t = 0,9$

$$P_{Gn} = P_{G3} \cdot f_t = 450 \cdot 0,9 = 405 \text{ Kw.}$$

Como $P_a < P_{Gn}$, es valido. Por lo tanto, necesita refrigeración por serpentín*

*solicitar dimensiones.

Para simbología ver pág.: 42.

Para fórmulas ver pág.: 43.

EXAMPLE 2

We want to select a mechanism with the following characteristics:

Mechanism:	Speed gear unit.
Shafts position:	Perpendicular
Driven machine:	non-homogeneous liquids mixer.
Driving machine:	Electric motor.
Motor nominal power:	$P_1 = 22 \text{ Kw}$.
Absorbed power by the driven machine	$P_a = 17 \text{ Kw}$.
Motor nominal speed:	$n_1 = 1.500 \text{ rpm}$.
Nominal speed of the driven machine:	$n_2 = 15 \text{ rpm}$.
Transmission ratio:	$n_1 / n_2 = i_N = 100$
Service hours per day:	12
Starts per hour:	4
Running time ED:	80 %
Ambient temperature:	40° C
Lifetime (hours):	50.000

Method of determining the type and size

- Determination of the application factor f_a .

Load classification (page 5): II
 Factor f_1, f_2 and f_3 (page 6): $f_1 = 1,5; f_2 = 1,08; f_3 = 1,07$
 $f_a = f_1 \cdot f_2 \cdot f_3 = 1,5 \cdot 1,08 \cdot 1,07 = 1,73$

- Necessary nominal power P_{Nn}

$$P_{Nn} = P_a \cdot f_a = 17 \cdot 1,73 = 29.4 \text{ Kw.}$$

Note: If the absorbed power is unknown, use the formula with the motor power P_1 .

- Type and size

Because of the shafts position and the transmission ratio, we go to page 30. TTHV type.

With the transmission ratio i_N , the speed n_1 and the necessary nominal power P_{Nn} , we select, with the condition $P_n \geq P_{Nn}$, the size 250, with $P_n = 30 \text{ Kw} > P_{Nn}$.

SELECTION: TTHV-250

Method of determining the cooling system

- Determination of the thermal factor f_t in page 6.

- **1st proof: without cooling.**
 $f_t = 0.9$

Necessary maximum thermal power P_{Gn} .

$$P_{Gn} = P_{G1} \cdot f_t = 95 \cdot 0,9 = 85.5 \text{ Kw.}$$

P_{G1}, P_{G2}, P_{G3} in page 30.

Valid if $P_a \leq P_{Gn}$.

As $P_a > P_{Gn}$, it is valid without cooling.

For symbols see page 42

For formulas see page 43

REDUCTORES TIPO TS / TS TYPE GEAR UNITS

UN TREN DE ENGRANAJES - EJES PARALELOS
SINGLE STAGE - PARALLEL SHAFTS



Relación de Transmisión i_N Transmission ratio	Velocidades r. p. m. Speeds		TAMAÑO REDUCTOR / GEAR UNIT SIZE															
	n_1	n_2	80	90	100	112	125	140	160	180	200	225	250	280	315	355	400	450
			Potencia P_N en Kw. / Power P_N in Kw.															
1	1.500	1.500	65	88	112	153	219	308	440	630	880	1.234						
	1.000	1.000	46	63	80	109	156	219	315	450	633	890						
	750	750	36	49	62	85	120	170	247	355	497	702						
1,12	1.500	1.339	59	80	102	138	193	279	400	573	799	1.105						
	1.000	892	42	56	72	97	139	199	285	410	574	796						
	750	669	33	44	56	76	107	155	224	322	452	627						
1,25	1.500	1.200	55	74	97	131	182	265	380	544	760	1.052						
	1.000	800	39	51	68	93	129	189	270	390	546	757						
	750	600	30	40	53	72	100	147	212	305	428	596						
1,40	1.500	1.071	51	70	92	115	173	235	345	467	670	920	1.250					
	1.000	714	36	49	65	80	122	167	246	334	480	660	898					
	750	535	27	38	50	63	96	130	192	260	376	520	708					
1,60	1.500	937	44	60	78	108	148	218	324	438	620	857	1.150	1.550	2.190	3.088		
	1.000	625	31	43	55	76	105	155	230	312	443	614	825	1.115	1.580	2.240		
	750	468	23	33	43	59	80	120	180	245	348	485	650	880	1.250	1.775		
1,80	1.500	833	39	54	75	100	136	207	300	410	593	800	1.100	1.456	2.060	2.900		
	1.000	555	28	39	53	70	96	146	214	290	423	572	790	1.050	1.490	2.095		
	750	416	22	31	42	56	76	116	168	230	335	455	630	835	1.190	1.680		
2	1.500	750	36	51	70	95	123	193	260	386	560	755	1.040	1.375	1.936	2.746		
	1.000	500	26	36	50	66	90	136	185	274	400	538	746	988	1.395	1.985		
	750	375	19	28	38	53	72	106	147	220	313	430	600	795	1.125	1.578		
2,25	1.500	666	33	48	64	86	120	173	243	359	506	696	976	1.290	1.815	2.500		
	1.000	444	23	34	45	60	84	122	173	256	360	500	725	930	1.300	1.800		
	750	333	17	25	34	46	66	95	138	200	280	390	546	750	1.025	1.420		
2,50	1.500	600	29	43	56	76	108	152	220	318	450	625	870	1.190	1.615	2.230		
	1.000	400	19	30	39	53	76	107	156	225	320	445	620	855	1.160	1.600		
	750	300	14	23	30	42	60	83	122	176	250	346	485	670	910	1.265		
2,80	1.500	535	25	36	50	65	94	135	193	280	395	545	760	1.050	1.410	1.960	2.765	
	1.000	357	17	24	34	46	65	94	136	197	280	390	542	750	1.010	1.410	1.990	
	750	267	13	19	27	35	50	75	105	155	220	300	425	586	790	1.105	1.570	
3,15	1.500	476	21	29	42	58	83	117	170	245	340	480	655	910	1.245	1.725	2.435	
	1.000	317	15	20	30	40	58	82	120	172	240	342	465	647	888	1.240	1.750	
	750	238	11	16	23	31	45	64	93	135	190	270	365	505	700	970	1.375	
3,55	1.500	422	18	25	38	52	70	103	150	210	290	405	560	790	1.100	1.515	2.045	2.845
	1.000	281	12	17	25	35	49	70	104	147	205	290	395	560	785	1.085	1.465	2.045
	750	211	10	13	19	26	38	55	78	115	158	225	308	440	615	850	1.200	1.610
4	1.500	375	16	22	34	46	64	89	133	183	260	356	507	668	960	1.290	1.775	2.515
	1.000	250	11	16	22	30	45	63	92	128	183	252	360	493	692	940	1.270	1.590
	750	187	9	12	17	24	34	48	72	100	142	195	280	370	580	720	1.050	1.415
4,50	1.500	333	14	19	30	42	53	78	118	164	220	317	428	595	850	1.140	1.580	2.125
	1.000	222	10	14	20	28	37	53	82	110	156	216	305	438	615	840	1.120	1.540
	750	166	8	11	15	21	29	40	62	86	120	168	235	328	465	630	935	1.190
5	1.500	300	13	18	27	37	50	70	106	150	192	284	380	540	790	1.020	1.420	2.050
	1.000	200	9	13	18	24	35	48	74	100	141	195	273	395	554	750	1.000	1.430
	750	150	7	10	14	18	25	35	56	77	106	151	210	296	420	565	840	1.060
5,60	1.500	267	11	16	24	33	45	63	95	132	173	256	340	490	710	920	1.275	1.830
	1.000	178	8	11	16	21	29	42	66	90	126	174	242	352	495	680	900	1.270
	750	133	6	8,5	12	16	22	32	50	69	95	135	183	265	376	505	750	950
6,30	1.500	238	10	14	21	30	40	56	85	118	154	228	305	440	630	820	1.130	1.630
	1.000	158	7	10	14	18	26	38	59	80	112	155	216	314	440	600	800	1.130
	750	119	5,5	7,5	11	14	20	29	44	62	85	120	164	235	335	450	670	850

Reductores con engrase a presión.
Variación máxima de la relación de transmisión $\pm 3\%$ (se pueden solicitar variaciones más restringidas).
A petición se consiguen relaciones de transmisión intermedias.

Gear units with forced lubrication.
Maximum variation for transmission ratio $\pm 3\%$. (More limited variations can be requested).
By request intermediate transmission ratios are obtained.

i_N	r. p. m. n_1	TAMAÑO REDUCTOR / GEAR UNIT SIZE																
		80	90	100	112	125	140	160	180	200	225	250	280	315	355	400	450	
		Potencia límite térmica P_G en Kw. / Maximum thermal capacity P_G in Kw.																
		P_{G1} para reductores sin refrigeración / P_{G1} for gear units without cooling.																
1 a 2,8	1.500	23	30	37	45	55	72	90	118	146	186	220	290	360	460	580		
	1.000	21	28	35	43	53	69	85	113	140	175	216	280	355	450	560		
	750	19	25	30	40	50	65	82	105	130	165	210	275	350	440	550		
3,15 a 6,3	1.500	20	27	34	43	52	69	86	108	135	172	213	280	350	440	550	680	
	1.000	17	23	29	39	49	63	79	104	128	163	205	265	340	430	540	670	
	750	15	20	25	37	46	56	75	98	122	150	200	245	330	420	520	660	
		P_{G2} para reductores con refrigeración por ventilador / P_{G2} for gear units with fan cooling.																
1 a 2,8	1.500	41	52	65	80	102	128	155	205	260	325	390	508	630	800	900		
	1.000	33	43	54	70	85	105	135	175	220	270	335	440	540	700	870		
	750	29	36	45	61	75	96	120	155	193	245	300	408	500	640	800		
3,15 a 6,3	1.500	34	45	58	72	92	118	148	190	238	300	378	485	600	770	960	1.210	
	1.000	28	36	45	58	76	97	122	160	200	258	320	418	525	670	845	1.040	
	750	24	32	40	52	68	85	105	145	180	225	290	360	475	600	750	970	
		P_{G3} para reductores con refrigeración por serpentín / P_{G3} for gear units with coil cooling.																
1 a 2,8	1.500	75	82	115	160	295	315	330	421	450	485	650	718	785	1.235	1.350		
	1.000	70	76	105	145	290	312	325	418	446	480	645	710	780	1.230	1.340		
	750	69	74	100	116	286	305	320	410	435	470	635	708	775	1.220	1.330		
3,15 a 6,3	1.500							326	412	438	480	640	708	775	1.220	1.330	1.470	
	1.000							300	405	433	470	635	695	765	1.210	1.320	1.460	
	750							285	400	430	462	625	678	755	1.190	1.300	1.450	
		P_{G4} para reductores con refrigeración por ventilador y serpentín / P_{G4} for gear units with fan and coil cooling.																
1 a 2,8	1.500								510	565	635	820	935	1.055	1.580	1.690		
	1.000								480	530	580	765	865	978	1.480	1.640		
	750								450	500	560	730	835	935	1.420	1.580		
3,15 a 6,3	1.500											800	918	1.035	1.550	1.740	1.980	
	1.000												845	955	1.440	1.620	1.830	
	750													750	850	1.390	1.540	1.750

Equipamientos Técnicos Comerciales, S.A. se reserva el derecho de realizar cualquier modificación. / Equipamientos Técnicos Comerciales, S.A. reserves the right to modification.

REDUCTORES TIPO TS / TS TYPE GEAR UNITS

UN TREN DE ENGRANAJES - EJES PARALELOS
SINGLE STAGE - PARALLEL SHAFTS

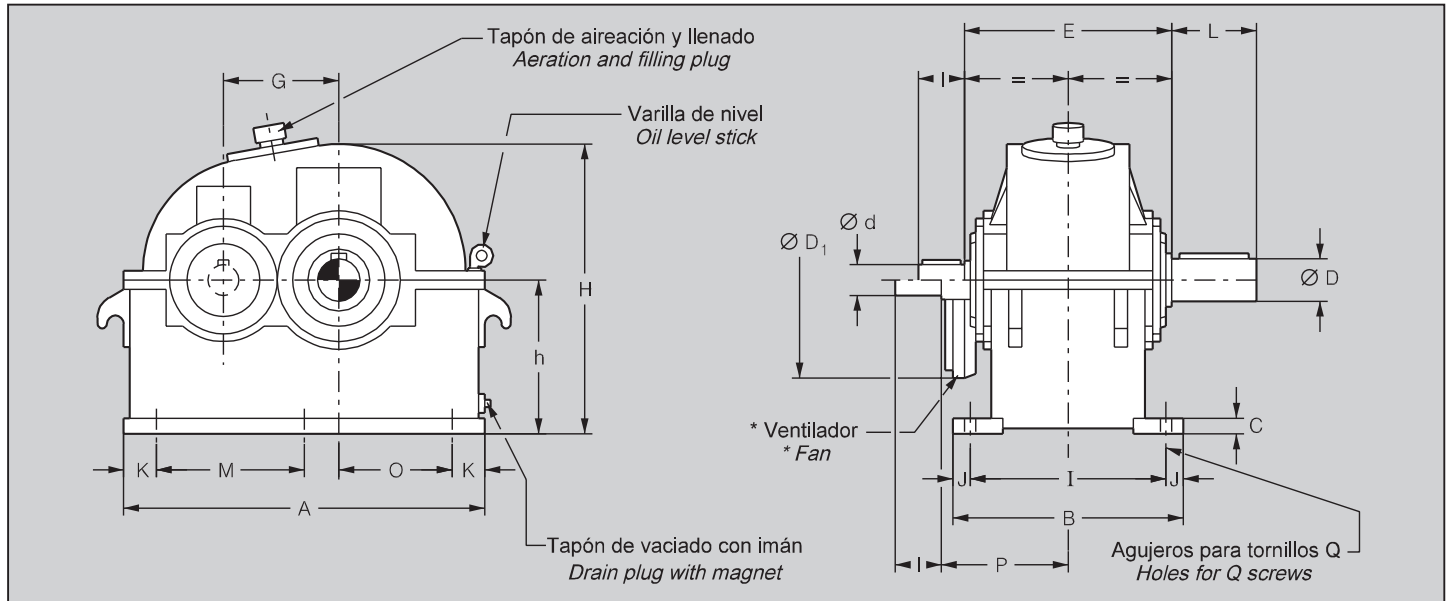

Extremos de árboles con chavetas DIN 6885 h1. Dimensiones: Pág 41.
 Puntos de centrado con rosca forma D DIN 332. Dimensiones: Pág 41.
 Tolerancia en extremos de árboles: Hasta Ø50 mm. ISO k6., superiores ISO m6.
 * Situación orientativa. Si necesita ventilador se estudiará, en cada caso, la situación idónea.
 1) Hasta 250 mm., tolerancia -0,5, superiores -1
 2) Solamente para posición de trabajo B3.

Shafts ends with keys to DIN 6885 h1. Dimensions: page 41.
 Centering points with thread to D DIN 332. Dimensions: page 41.
 Tolerance of shaft ends: up to Ø50 mm. ISO k6., bigger ones ISO m6.
 * Approximated situation. If fan is needed, the suitable situation will be studied in every case.
 1) Up to 250 mm.. tolerance - 0.5, bigger ones -1.
 2) Only for working position B3.
 N= Number of holes of the base.

Tamaño Reductor Gear unit size	A	B	C	$i_N \leq 2,8$		$i_N 3,15 \pm 4,5$		$i_N > 4,5$		D	L	D_1	E	G	h ₁₎	H	I	J	K	M	N	O	P	Q	Peso = / Kg. Weight = / Kg.	Capacidad de aceite = / l. Quantity of oil = / l. 2)
				d	l	d	l	d	l																	
80	240	170	14	30	80	25	60	20	50	35	80	160	174	80	112	182	142	14	22	196	4	70	124	M10	20	1,2
90	270	188	14	35	80	30	80	25	60	40	110	180	194	90	125	205	160	14	22	226	4	81	134	M10	25	1,8
100	300	210	16	40	110	35	80	25	60	45	110	180	216	100	140	228	178	16	25	250	4	90	145	M12	35	2,5
112	335	240	16	45	110	35	80	30	80	50	110	230	248	112	160	272	210	15	25	285	4	101	171	M14	50	4
125	385	275	18	50	110	40	110	30	80	55	110	230	271	125	180	313	239	18	28	329	4	121,5	183	M14	70	5,5
140	430	295	20	55	110	45	110	35	80	65	140	230	295	140	200	347	259	18	28	374	4	140,5	195	M14	100	7
160	470	320	25	65	140	50	110	40	110	75	140	300	316	160	225	387	280	20	30	205	6	150	218	M16	130	8,5
180	525	360	26	70	140	55	110	45	110	80	170	300	346	180	250	427	320	20	30	232,5	6	170	233	M16	180	11
200	585	400	28	75	140	60	140	50	110	90	170	340	381	200	280	485	352	24	35	257,5	6	190	260	M18	242	18
225	660	450	30	85	170	70	140	55	110	100	210	340	412	225	315	537	396	27	40	290	6	213	276	M20	329	25
250	730	500	35	90	170	75	140	60	140	110	210	410	453	250	355	607	440	30	45	320	6	235	310	M22	453	36
280	820	542	40	100	210	85	170	70	140	130	250	410	485	280	400	720	482	30	55	355	6	268	326	M24	623	45
315	904	590	45	110	210	95	170	80	170	140	250	500	531	315	450	800	520	35	70	382	6	284	365	M30	853	67
355	980	635	50	130	250	110	210	85	170	160	300	500	565	355	500	875	565	35	80	410	6	300	383	M30	1.153	80
400	1.104	695	50	140	250	120	210	95	170	180	300	700	622	400	560	980	605	45	95	457	6	331	440	M36	1.523	116
450	1.244	760	63	—	—	130	250	110	210	200	350	700	678	450	630	1.098	670	45	105	517	6	375	470	M36	2.150	155

Posiciones de trabajo Working positions

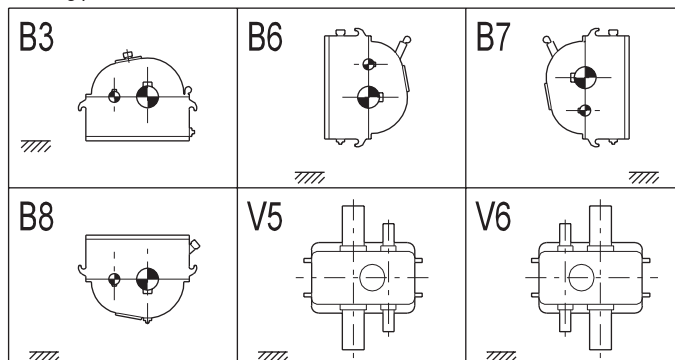

Posición extremos de árboles y Sentidos de giro Shafts position and direction of rotation

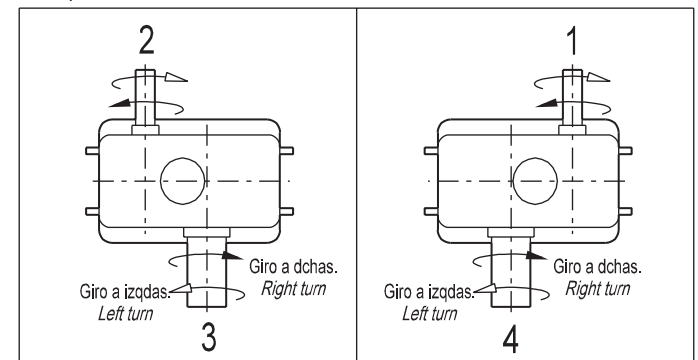

REDUCTORES TIPO TD-TDA-PDA-TDPV / TD-TDA-PDA-TDPV TYPE GEAR UNITS



DOS TRENES DE ENGRANAJES - EJES PARALELOS

TWO STAGES - PARALLEL SHAFTS

Relación de transmis. i_N Transmission ratio	Velocidades r. p. m. / Speeds		TAMAÑO REDUCTOR / GEAR UNIT SIZE																	
	n_1	n_2	112	125	140	160	180	200	225	250	280	315	355	400	450	500	560	630	710	800
			Potencia P_N en Kw. / Power P_N in Kw.																	
7,1	1.500	210	36	50	70	105	150	205	295	400	555	735	1.125	1.525	2.200	3.350	4.700	6.600		
	1.000	140	24	34	48	70	100	136	200	265	370	490	750	1.020	1.470	2.235	3.135	4.400	6.150	
	750	106	18	26	36	52	75	102	150	200	280	370	560	765	1.100	1.680	2.350	3.300	4.615	6.150
8	1.500	185	32	46	67	95	135	185	265	365	505	695	1.025	1.360	1.920	3.060	4.350	5.900		
	1.000	125	21	31	45	65	90	123	180	245	340	465	685	910	1.280	2.035	2.900	3.935	5.700	
	750	94	16	23	34	49	67	92	135	185	255	350	515	685	960	1.530	2.175	2.950	4.275	5.780
9	1.500	167	29	42	60	86	125	170	242	330	455	655	910	1.230	1.750	2.850	3.900	5.150		
	1.000	111	19	28	40	58	83	113	162	220	305	440	610	820	1.170	1.900	2.600	3.435	5.000	
	750	83	15	21	30	44	62	85	122	165	230	330	460	615	880	1.425	1.950	2.580	3.750	5.200
10	1.500	150	26	37	52	78	105	154	218	290	400	580	805	1.130	1.580	2.500	3.550	4.650		
	1.000	100	17	24	35	52	70	105	145	195	270	390	540	750	1.055	1.670	2.370	3.100	4.550	
	750	75	13	19	26	39	52	79	110	146	200	290	405	565	790	1.250	1.780	2.325	3.415	4.750
11,2	1.500	134	23	32	45	69	96	140	195	260	365	530	745	975	1.400	2.270	3.180	4.200		
	1.000	89	15	21	30	46	64	95	130	175	245	355	500	650	935	1.515	2.120	2.800	4.100	
	750	67	11,5	16	22	34,5	48	70	100	130	185	270	375	490	700	1.140	1.590	2.100	3.075	4.400
12,5	1.500	120	21	28	40	60	82	110	170	230	325	455	650	880	1.230	2.030	2.800	3.800	5.150	
	1.000	80	14	19	26	40	55	75	115	155	220	305	435	590	820	1.355	1.870	2.535	3.435	
	750	60	10	14	20	30	41	56	86	115	165	230	330	445	615	1.020	1.400	1.900	2.580	3.800
14	1.500	107	19	26	37	50	74	105	155	205	280	400	585	800	1.080	1.800	2.520	3.320	4.800	
	1.000	71	12	17	25	33	50	70	105	135	190	270	390	535	720	1.200	1.680	2.215	3.200	
	750	54	9,5	13	18,7	24,7	37,5	52	80	100	145	200	295	400	540	900	1.260	1.660	2.400	3.400
16	1.500	94	16	21	30	47	66	96	135	185	255	355	520	705	985	1.580	2.250	3.000	4.350	
	1.000	62	10,5	14	20	31	44	65	90	125	170	240	350	470	660	1.055	1.500	2.000	2.900	
	750	47	8	11	15	23,2	33	50	70	95	130	180	265	355	495	790	1.125	1.500	2.250	2.950
18	1.500	83	14	19	28	41	60	86	120	160	230	335	465	625	885	1.480	1.950	2.720	3.900	
	1.000	56	9,5	13	18	27	40	60	80	105	155	225	310	420	590	990	1.300	1.815	2.600	
	750	42	7	10	13,5	20,2	30	45	60	78	120	170	235	315	445	745	975	1.360	2.175	2.800
20	1.500	75	13	17	25	39	56	76	110	145	210	290	390	545	755	1.230	1.740	2.370	3.450	
	1.000	50	8,5	11,5	17	26	37	50	75	97	140	195	260	365	505	820	1.160	1.580	2.300	
	750	38	6,5	8,5	12,7	19,5	27,7	37	55	72	105	150	195	275	380	615	870	1.185	1.725	2.500
22,5	1.500	67	11,5	15	22	32	42	64	95	130	180	255	350	480	720	1.120	1.530	2.150	3.020	
	1.000	44	7,5	10	15	21	28	43	65	87	120	170	235	320	480	750	1.020	1.435	2.015	
	750	33	6	7,5	11,2	15,7	21	32	50	65	90	130	180	240	360	565	765	1.080	1.510	2.150

Reductores con engrases a presión.
Variación máxima de la relación de transmisión $\pm 3\%$ (se pueden solicitar variaciones más restringidas).
A petición se consiguen relaciones de transmisión intermedias.

Gear units with forced lubrication.
Maximum variation for transmission ratio $\pm 3\%$. (More limited variations can be requested).
By request intermediate transmission ratios are obtained.

i_N	r. p. m. n_1	TAMAÑO REDUCTOR / GEAR UNIT SIZE																		
		112	125	140	160	180	200	225	250	280	315	355	400	450	500	560	630	710	800	
Potencia límite térmica P_G en Kw. / Maximum thermal capacity P_G in Kw.																				
P_{G1} para reductores sin refrigeración / P_{G1} for gear units without cooling.																				
7,1 a 11,2	1.500	30	38	48	60	76	95	120	150	190	230	295	370	465	590	750	950	1.180		
	1.000	26	34	42	53	68	90	112	140	180	220	280	360	450	575	740	930	1.150		
	750	24,5	32	39	50	64	83	108	130	170	215	270	350	440	565	730	910	1.120	1.460	
12,5 a 22,5	1.500	25	33	42	54	70	90	115	140	180	225	280	360	450	575	740	930	1.150		
	1.000	21,5	28	36	46	61	79	105	130	170	220	270	350	435	565	730	910	1.135		
	750	20	26	33	42	55	74	95	120	160	210	265	340	425	550	720	900	1.120	1.430	
P_{G2} para reductores con refrigeración por ventilador / P_{G2} for gear units with fan cooling.																				
7,1 a 11,2	1.500	50	65	80	105	125	160	195	240	310	390	480	610	780	970	1.240	1.550			
	1.000	40	52	64	80	102	135	170	210	270	345	420	530	680	860	1.100	1.400	1))		
	750	34	45	55	70	90	120	150	190	240	310	390	490	630	800	1.000	1.300			
12,5 a 22,5	1.500				90	115	150	185	230	290	380	470	590	750	940	1.180	1.500			
	1.000				68	90	120	155	190	250	330	400	510	660	850	1.060	1.380	1))		
	750				60	80	100	135	170	215	280	360	480	600	780	980	1.300			
P_{G3} para reductores con refrigeración por serpentín / P_{G3} for gear units with coil cooling.																				
$\leq 22,5$	1.500					170	190	330	360	400	450	530	780	870	990	1.150	1.370			
	1.000					160	180	320	350	390	430	510	760	860	980	1.140	1.360	1))		
	750					155	175	315	345	380	425	495	750	850	970	1.130	1.345			
P_{G4} para reductores con refrigeración por ventilador y serpentín / P_{G4} for gear units with fan and coil cooling.																				
$\leq 22,5$	1.500					260	420	450	550	620	720	1.025	1.195	1.400	1.650	2.080				
	1.000					235	395	430	500	580	650	950	1.095	1.300	1.530	2.000	1))			
	750					220	350	410	470	540	630	900	1.050	1.200	1.450	1.800				

(1) Refrigeración bajo consulta.

(1) Cooling on request.

Equipamientos Técnicos Comerciales, S.A. se reserva el derecho de realizar cualquier modificación. / Equipamientos Técnicos Comerciales, S.A. reserves the right to modification.

REDUCTORES TIPO TD / TD TYPE GEAR UNITS



DOS TRENES DE ENGRANAJES - EJES PARALELOS
TWO STAGES - PARALLEL SHAFTS

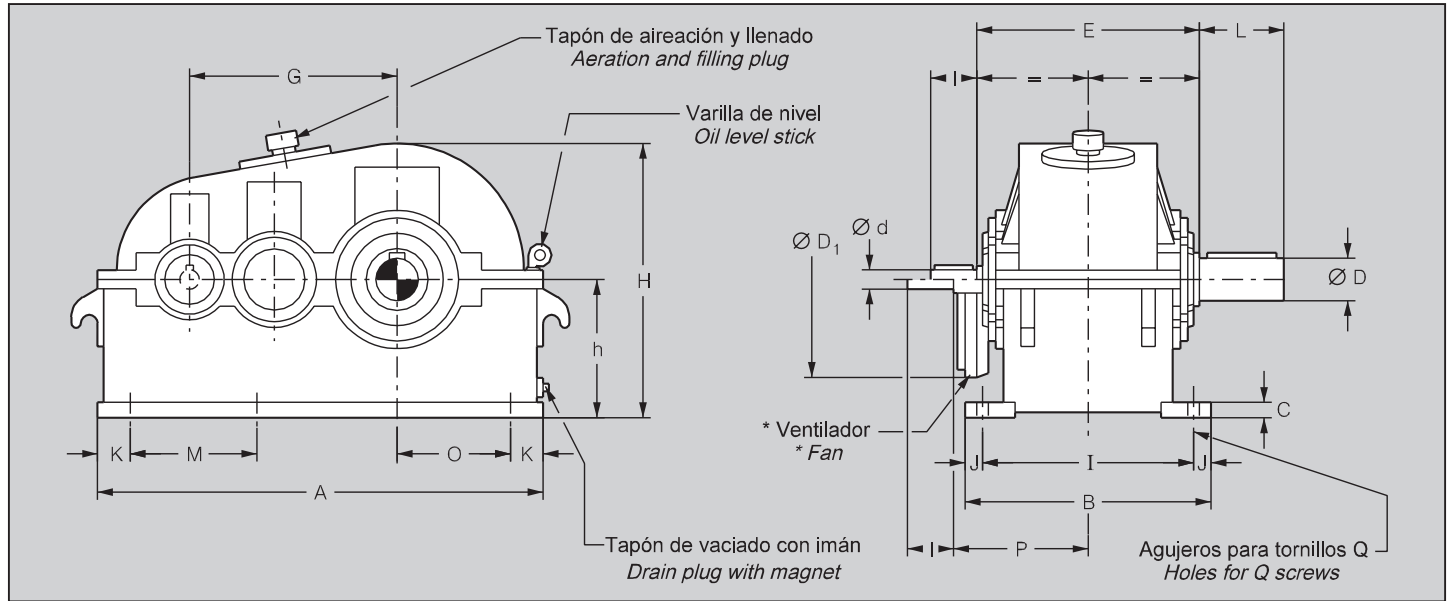

Extremos de árboles con chavetas DIN 6885 h1. Dimensiones: Pág 41.

Puntos de centrado con rosca forma D DIN 332. Dimensiones: Pág 41.

Tolerancia en extremos de árboles: Hasta Ø50 mm. ISO k6., superiores ISO m6.

* Situación orientativa. Si necesita ventilador se estudiará, en cada caso, la situación idónea.

1) Hasta 250 mm., tolerancia -0,5, superiores -1

2) Solamente para posición de trabajo B3.

N = Cantidad de agujeros en la base.

Shafts ends with keys to DIN 6885 h1. Dimensions: page 41.

Centering points with thread to D DIN 332. Dimensions: page 41.

Tolerance of shaft ends: up to Ø50 mm. ISO k6, bigger ones ISO m6.

* Approximated situation. If fan is needed, the suitable situation will be studied in every case.

1) Up to 250 mm., tolerance - 0.5, bigger ones -1.

2) Only for working position B3.

N= Number of holes of the base.

Tamaño Reductor Gear unit size	A	B	C	$i_N < 14$		$i_N \geq 14$		D	$\approx D_1$	E	G	h ₁₎	$\approx H$	I	J	K	L	M	N	O	P	Q	Peso = / Kg Weight = / Kg	Capacidad de aceite = / l. Quantity of oil = / l.
				d	l	d	l																	
112	418	252	14	30	80	20	50	55	180	246	192	125	262	220	16	24	110	185	6	122	163	M12	66	2,8
125	462	280	15	30	80	25	60	60	180	266	215	140	292	244	18	26	120	205	6	134	173	M14	85	4,6
140	516	314	16	35	80	30	80	65	230	296	240	160	332	274	20	30	140	228	6	149	195	M16	120	6,5
160	570	358	18	40	110	35	80	75	230	340	272	180	367	318	20	35	140	250	6	162	217	M16	167	10
180	640	392	20	45	110	35	80	85	230	366	305	200	409	348	22	40	170	280	6	178	230	M18	240	14
200	714	422	22	50	110	40	110	95	300	380	340	225	454	372	25	45	170	312	6	192	250	M20	336	19
225	802	468	25	55	110	45	110	110	300	420	385	250	504	412	28	50	210	234	8	213	270	M22	445	26
250	896	526	28	60	120	55	110	120	340	472	430	280	565	466	30	55	210	262	8	237	306	M24	555	37
280	1.002	558	31	65	140	60	120	130	340	514	480	315	636	498	30	60	250	294	8	269	327	M24	716	50
315	1.106	620	34	70	140	60	120	150	410	576	540	355	703	560	30	70	250	322	8	288	371	M24	980	66
355	1.240	690	36	85	140	70	140	170	410	634	605	400	775	626	32	80	300	270	10	320	400	M27	1.340	105
400	1.396	726	40	90	170	80	170	190	500	666	680	450	872	662	32	90	350	304	10	357	433	M27	1.780	140
450	1.564	804	43	100	210	85	170	210	500	744	765	500	967	734	35	100	350	341	10	399	472	M30	2.500	195
500	1.736	878	45	110	210	95	170	230	700	822	855	560	1.078	808	35	110	410	379	10	443	540	M30	3.460	275
560	1.950	978	48	120	210	110	210	260	700	902	960	630	1.212	902	38	120	410	342	12	502	580	M33	4.700	400
630	2.215	1.076	55	140	250	120	210	300	850	980	1.080	710	1.380	986	45	135	470	389	12	575	635	M36	6.280	550
710	2.480	1.184	62	170	300	140	250	330	850	1.088	1.210	800	1.550	1.094	45	150	470	436	12	640	689	M39	8.200	800
800	2.785	1.322	70	190	350	160	300	370	950	1.202	1.360	900	1.745	1.222	50	170	550	489	12	715	756	M42	10.300	1.150

Posiciones de trabajo
Working positions

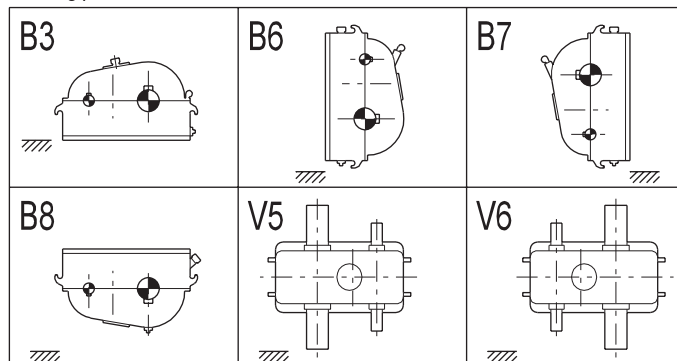

Posición extremos de árboles y Sentidos de giro
Shafts position and direction of rotation

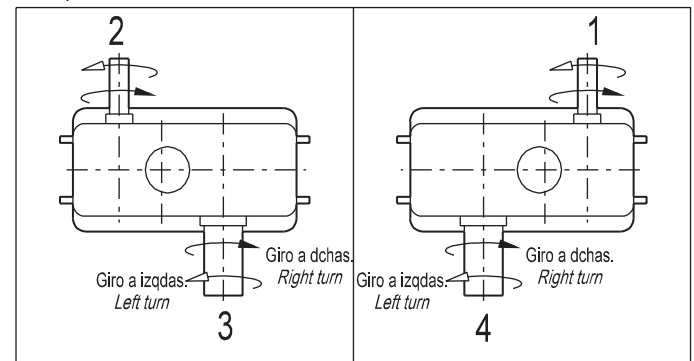

Equipamientos Técnicos Comerciales, S.A. se reserva el derecho de realizar cualquier modificación. / Equipamientos Técnicos Comerciales, S.A. reserves the right to modification.

REDUCTORES TIPO TDA / TDA TYPE GEAR UNITS



DOS TRENES DE ENGRANAJES - EJES PARALELOS - ARBOL LENTO HUECO
TWO STAGES - PARALLEL SHAFTS - HOLLOW SLOW SHAFT

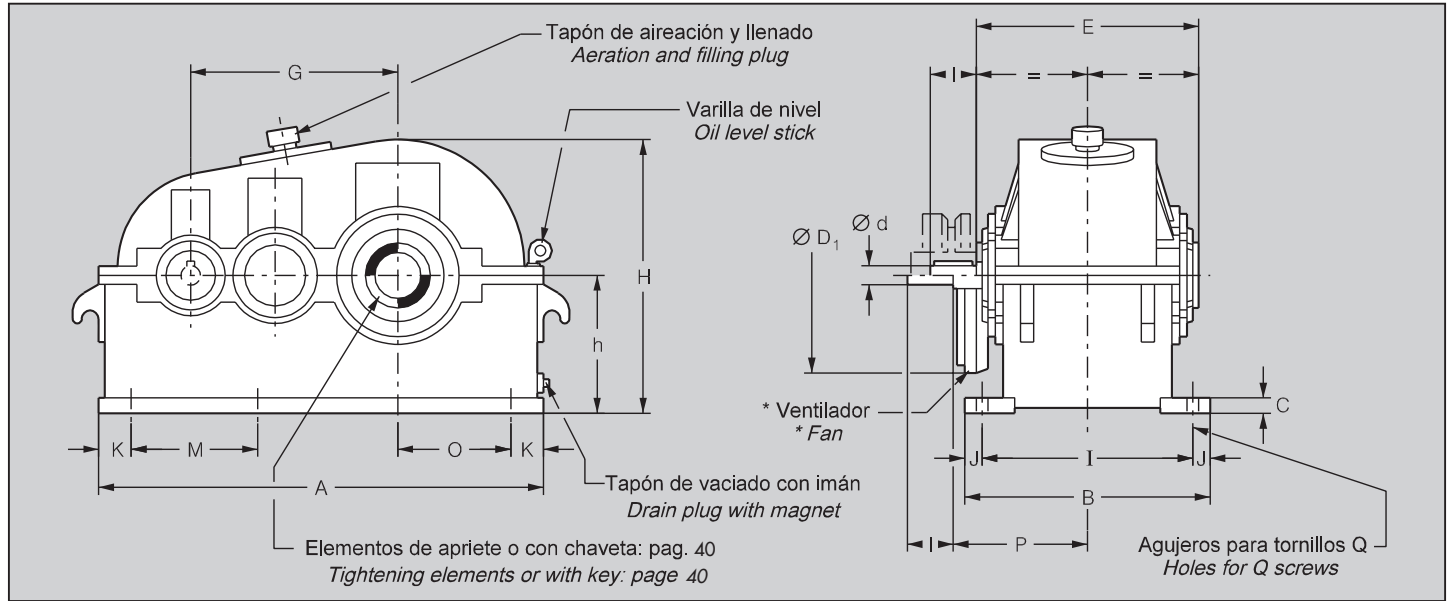

Extremos de árboles con chavetas DIN 6885 h1. Dimensiones: Pág 41.

Puntos de centrado con rosca forma D DIN 332. Dimensiones: Pág 41.

Tolerancia en extremos de árboles: Hasta Ø50 mm. ISO k6., superiores ISO m6.

* Situación orientativa. Si necesita ventilador se estudiará, en cada caso, la situación idónea.

1) Hasta 250 mm., tolerancia -0,5, superiores -1

2) Solamente para posición de trabajo B3.

N = Cantidad de agujeros en la base.

Shafts ends with keys to DIN 6885 h1. Dimensions: page 41.

Centering points with thread to D DIN 332. Dimensions: page 41.

Tolerance of shaft ends: up to Ø50 mm. ISO k6, bigger ones ISO m6.

* Approximated situation. If fan is needed, the suitable situation will be studied in every case.

1) Up to 250 mm., tolerance - 0.5, bigger ones - 1.

2) Only for working position B3.

N= Number of holes of the base.

Tamaño Reductor Gear unit size	A	B	C	$i_N < 14$		$i_N \geq 14$		\approx D ₁	E	G	h ₁₎	\approx H	I	J	K	M	N	O	P	Q	Peso = /Kg. Weight = /kg	Capacidad de aceite = /l. Quantity of oil = /l. 2)
				d	l	d	l															
112	418	252	14	30	80	20	50	180	246	192	125	262	220	16	24	185	6	122	163	M12	66	2,8
125	462	280	15	30	80	25	60	180	266	215	140	292	244	18	26	205	6	134	173	M14	85	4,6
140	516	314	16	35	80	30	80	230	296	240	160	332	274	20	30	228	6	149	195	M16	120	6,5
160	570	358	18	40	110	35	80	230	340	272	180	367	318	20	35	250	6	162	217	M16	167	10
180	640	392	20	45	110	35	80	230	366	305	200	409	348	22	40	280	6	178	230	M18	240	14
200	714	422	22	50	110	40	110	300	380	340	225	454	372	25	45	312	6	192	250	M20	336	19
225	802	468	25	55	110	45	110	300	420	385	250	504	412	28	50	234	8	213	270	M22	445	26
250	896	526	28	60	120	55	110	340	472	430	280	565	466	30	55	262	8	237	306	M24	555	37
280	1.002	558	31	65	140	60	120	340	514	480	315	636	498	30	60	294	8	269	327	M24	716	50
315	1.106	620	34	70	140	60	120	410	576	540	355	703	560	30	70	322	8	288	371	M24	980	66
355	1.240	690	36	85	140	70	140	410	634	605	400	775	626	32	80	270	10	320	400	M27	1.340	105
400	1.396	726	40	90	170	80	170	500	666	680	450	872	662	32	90	304	10	357	433	M27	1.780	140
450	1.564	804	43	100	210	85	170	500	744	765	500	967	734	35	100	341	10	399	472	M30	2.500	195
500	1.736	878	45	110	210	95	170	700	822	855	560	1.078	808	35	110	379	10	443	540	M30	3.460	275
560	1.950	978	48	120	210	110	210	700	902	960	630	1.212	902	38	120	342	12	502	580	M33	4.700	400
630	2.215	1.076	55	140	250	120	210	850	980	1.080	710	1.380	986	45	135	389	12	575	635	M36	6.280	550
710	2.480	1.184	62	170	300	140	250	850	1.088	1.210	800	1.550	1.094	45	150	436	12	640	689	M39	8.200	800
800	2.785	1.322	70	190	350	160	300	950	1.202	1.360	900	1.745	1.222	50	170	489	12	715	756	M42	10.300	1.150

Posiciones de trabajo
Working positions

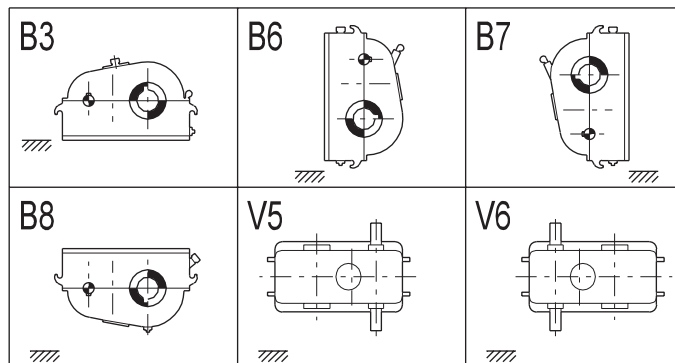

Posición extremos de árboles y Sentidos de giro
Shafts position and direction of rotation

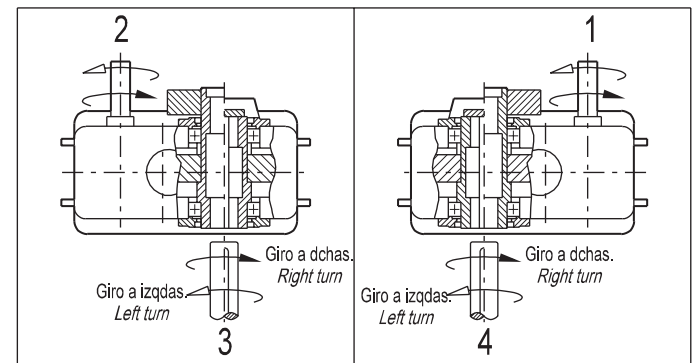

Equipamientos Técnicos Comerciales, S.A. se reserva el derecho de realizar cualquier modificación. / Equipamientos Técnicos Comerciales, S.A. reserves the right to modification.

REDUCTORES TIPO PDA / PDA TYPE GEAR UNITS



DOS TRENES DE ENGRANAJES - EJES PARALELOS - ARBOL LENTO HUECO
TWO STAGES - PARALLEL SHAFTS - HOLLOW SLOW SHAFT

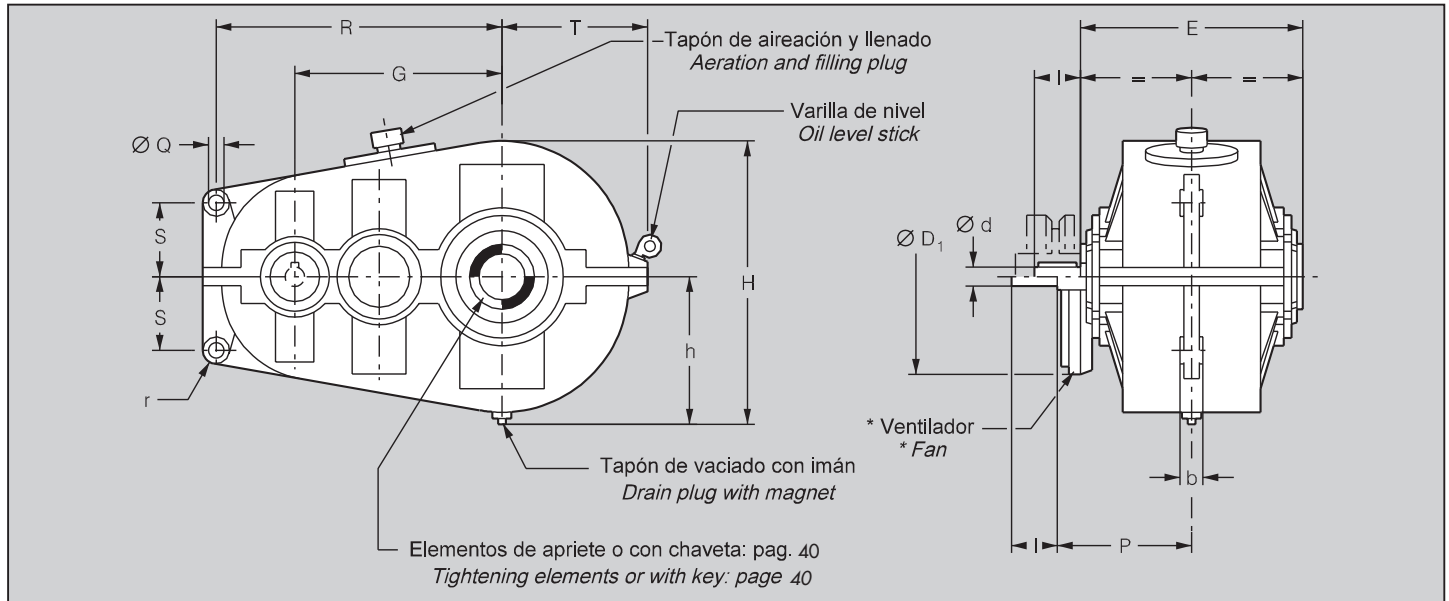

Extremos de árboles con chavetas DIN 6885 h1. Dimensiones: Pág 41.

Puntos de centrado con rosca forma D DIN 332. Dimensiones: Pág 41.

Tolerancia en extremos de árboles: Hasta Ø50 mm. ISO k6., superiores ISO m6.

* Situación orientativa. Si necesita ventilador se estudiará, en cada caso, la situación idónea.

1) Solamente para posición de trabajo B5.

Shafts ends with keys to DIN 6885 h1. Dimensions: page 41.

Centering points with thread to D DIN 332. Dimensions: page 41.

Tolerance of shaft ends: up to Ø50 mm. ISO k6, bigger ones ISO m6.

* Approximated situation. If fan is needed, the suitable situation will be studied in every case.

1) Only for working position B5.

Tamaño Reductor Gear unit size	b	$i_N < 14$		$i_N \geq 14$		$\approx D_1$	E	G	$\approx h$	$\approx H$	P	Q	r	R	S	T	Peso = / Kg. Weight = / Kg.	Capacidad de aceite = / l. Quantity of oil = / l. 1)
		d	l	d	l													
112	18	30	80	20	50	180	246	192	143	280	163	16	16	263	80	153	61	1
125	20	30	80	25	60	180	266	215	158	310	173	18	18	291	90	167	78	1,7
140	22	35	80	30	80	230	296	240	178	350	195	18	18	327	95	187	110	2,2
160	25	40	110	35	80	230	340	272	193	376	217	20	20	361	105	205	147	3,5
180	28	45	110	35	80	230	366	305	215	424	230	25	25	404	120	225	206	5
200	32	50	110	40	110	300	380	340	235	464	250	25	25	463	130	247	278	7
225	35	55	110	45	110	300	420	385	260	514	270	28	28	523	145	275	373	11
250	44	60	120	55	110	340	472	430	293	578	306	28	28	591	165	305	478	15
280	44	65	140	60	120	340	514	480	329	650	327	30	30	657	185	343	626	18
315	48	70	140	60	120	410	576	540	356	704	371	35	35	728	200	373	872	21
355	55	85	140	70	140	410	634	605	383	758	400	40	40	800	210	400	1.205	37
400	60	90	170	80	170	500	666	680	430	852	433	45	45	904	235	447	1.570	53
450	70	100	210	85	170	500	744	765	477	944	472	50	50	1.015	250	499	2.190	69
500	80	110	210	95	170	700	822	855	528	1.046	540	55	55	1.128	285	553	3.100	96
560	90	120	210	110	210	700	902	960	592	1.174	580	60	60	1.268	330	622	3.950	140
630	100	140	250	120	210	850	980	1.080	682	1.352	635	70	75	1.430	370	710	5.100	190
710	110	170	300	140	250	850	1.088	1.210	762	1.512	689	80	85	1.605	415	790	7.000	280
800	120	190	350	160	300	950	1.202	1.360	857	1.702	756	90	95	1.805	470	885	9.300	400

Posiciones de trabajo
Working positions

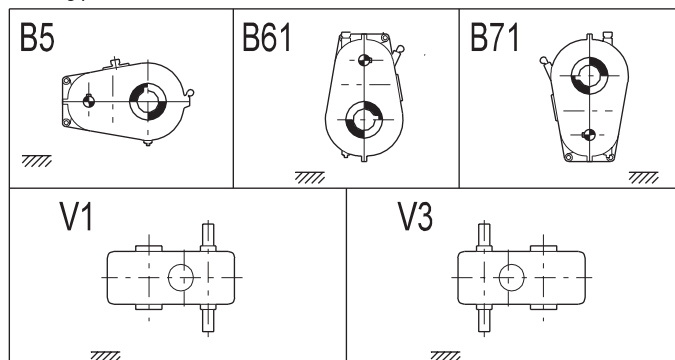

Posición extremos de árboles y Sentidos de giro
Shafts position and direction of rotation

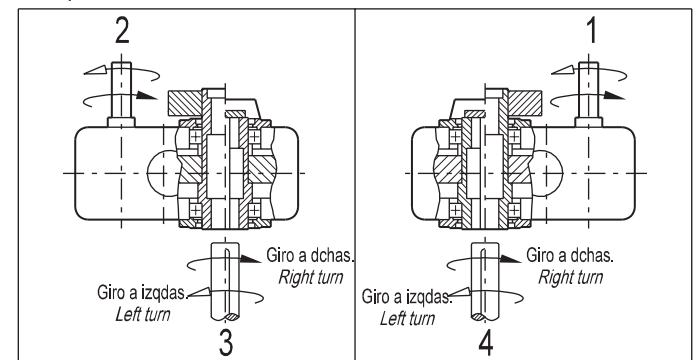

Equipamentos Técnicos Comerciales, S.A. se reserva el derecho de realizar cualquier modificación. / Equipamentos Técnicos Comerciales, S.A. reserves the right to modification.

REDUCTORES TIPO TDPV / TDPV TYPE GEAR UNITS



DOS TRENES DE ENGRANAJES - EJES PARALELOS
TWO STAGES - PARALLEL SHAFTS

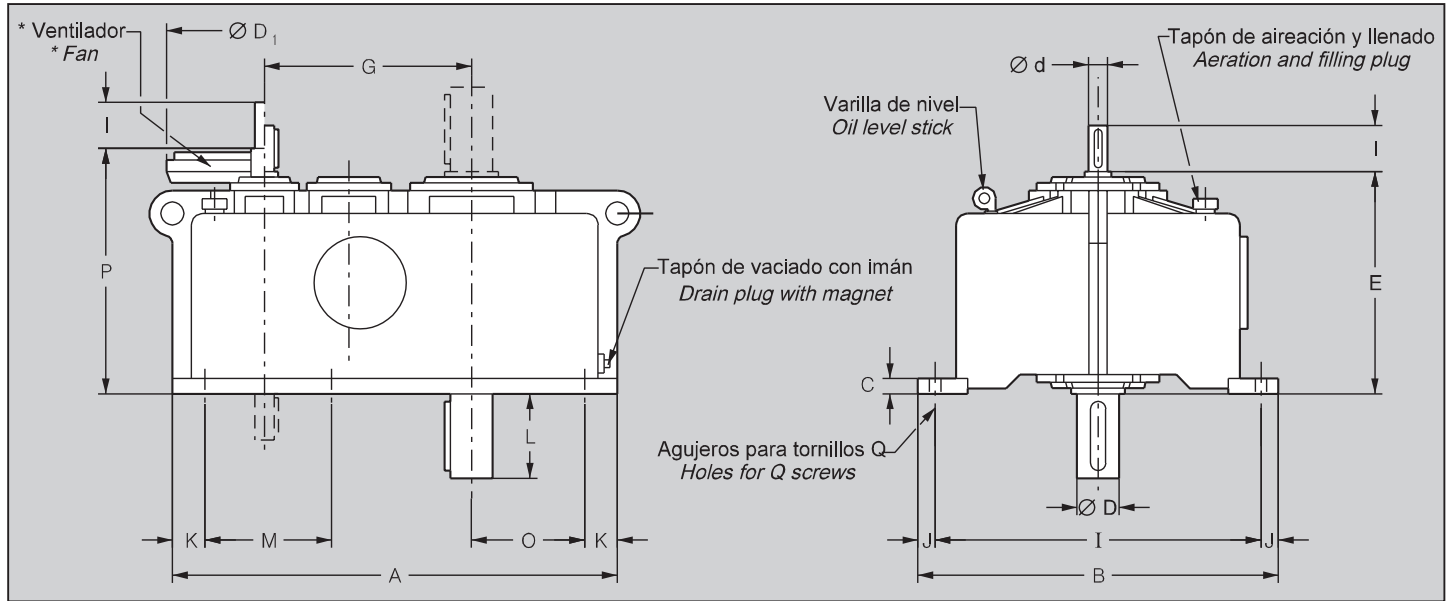

Extremos de árboles con chavetas DIN 6885 h1. Dimensiones: Pág 41.
 Puntos de centrado con rosca forma D DIN 332. Dimensiones: Pág 41.
 Tolerancia en extremos de árboles: Hasta Ø50 mm. ISO k6., superiores ISO m6.
 * Situación orientativa. Si necesita ventilador se estudiará, en cada caso, la situación idónea.
 1) Solamente para posición de trabajo V11 y V31.
 N = Cantidad de agujeros en la base.

Shafts ends with keys to DIN 6885 h1. Dimensions: page 41.
 Centering points with thread to D DIN 332. Dimensions: page 41.
 Tolerance of shaft ends: up to Ø50 mm. ISO k6, bigger ones ISO m6.
 * Approximated situation. If fan is needed, the suitable situation will be studied in every case.
 1) Only for working position V11 y V31.
 N= Number of holes of the base.

Tamaño Reductor Gear unit size	A	B	C	i _N < 14		i _N ≥ 14		D	D ₁	E	G	I	J	K	L	M	N	O	P	Q	Peso = / Kg. Weight = / Kg.	Capacidad de aceite = / l. Quantity of oil = / l.
				d	l	d	l															
112	418	336	14	30	80	20	50	55	180	246	192	304	16	24	110	185	6	122	286	M12	72	5
125	462	376	15	30	80	25	60	60	180	266	215	340	18	26	120	205	6	134	306	M14	92	7
140	516	420	16	35	80	30	80	65	230	296	240	380	20	30	140	228	6	149	343	M16	130	9
160	570	462	18	40	110	35	80	75	230	340	272	422	20	35	140	250	6	162	387	M16	180	15
180	640	510	20	45	110	35	80	85	230	366	305	466	22	40	170	280	6	178	413	M18	260	20
200	714	574	22	50	110	40	110	95	300	380	340	524	25	45	170	312	6	192	440	M20	364	27
225	802	630	25	55	110	45	110	110	300	420	385	574	28	50	210	234	8	213	480	M22	480	38
250	896	700	28	60	120	55	110	120	340	472	430	640	30	55	210	262	8	237	542	M24	600	52
280	1.002	758	31	65	140	60	120	130	340	514	480	698	30	60	250	294	8	269	584	M24	770	74
315	1.106	828	34	70	140	60	120	150	410	576	540	768	30	70	250	322	8	288	659	M24	1.050	102
355	1.240	914	36	85	140	70	140	170	410	634	605	850	32	80	300	270	10	320	717	M27	1.450	147
400	1.396	1.036	40	90	170	80	170	190	500	666	680	972	32	90	350	304	10	357	766	M27	1.920	206
450	1.564	1.136	43	100	210	85	170	210	500	744	765	1.066	35	100	350	341	10	399	844	M30	2.680	298
500	1.736	1.240	45	110	210	95	170	230	700	822	855	1.170	35	110	410	379	10	443	951	M30	3.690	387
560	1.950	1.404	48	120	210	110	210	260	700	902	960	1.328	38	120	410	342	12	502	1.031	M33	5.000	575
630	2.215	1.570	55	140	250	120	210	300	850	980	1.080	1.480	45	135	470	389	12	575	1.125	M36	6.650	819
710	2.480	1.716	62	170	300	140	250	330	850	1.088	1.210	1.626	45	150	470	436	12	640	1.233	M39	8.650	1.145
800	2.785	1.896	70	190	350	160	300	370	950	1.202	1.360	1.796	50	170	550	489	12	715	1.357	M42	10.850	1.600

Posiciones de trabajo
Working positions

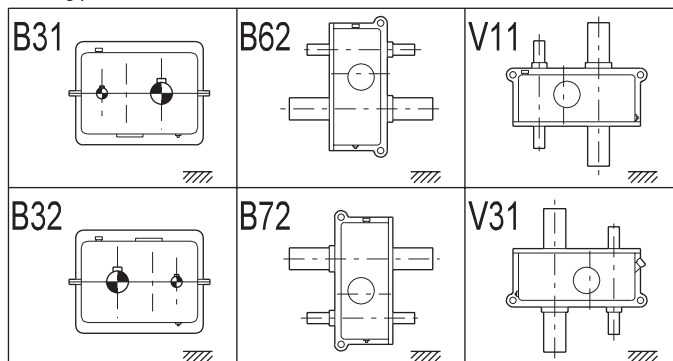

Posición extremos de árboles y Sentidos de giro
Shafts position and direction of rotation

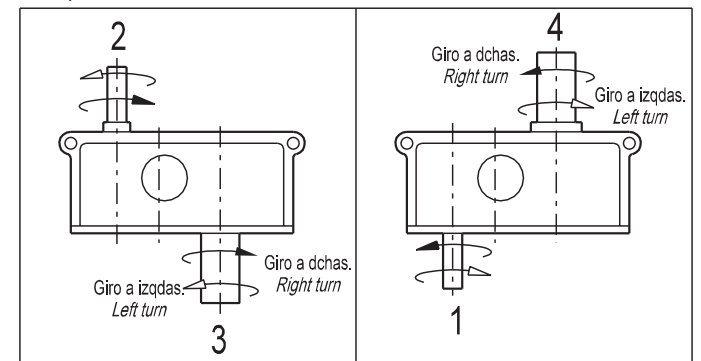

Equipamientos Técnicos Comerciales, S.A. se reserva el derecho de realizar cualquier modificación. / Equipments Technical Commercial, S.A. reserves the right to modification.

REDUCTORES TIPO TT-TTA-PTA-TTPV / TT-TTA-PTA-TTPV TYPE GEAR UNITS



TRES TRENES DE ENGRANAJES - EJES PARALELOS
THREE STAGES - PARALLEL SHAFTS

Relación de transm. i_N Transmission ratio	Velocidades r. p. m. Speeds n_1 n_2		TAMAÑO REDUCTOR / GEAR UNIT SIZE															
			140	160	180	200	225	250	280	315	355	400	450	500	560	630	710	800
			Potencia P_N en Kw. / Power P_N in Kw.															
22,5	1.500	67	23	36	53	70	95	135	185	275	405	540	790	1.200	1.630	2.400	3.200	4.300
	1.000	44	15,5	24	35	45	65	90	125	185	270	360	530	800	1.090	1.600	2.135	3.000
	750	33	12	18	26	33,5	48	67	94	140	200	270	400	600	820	1.200	1.600	2.250
25	1.500	60	20	32	47	62	90	120	160	245	365	480	700	1.060	1.500	2.000	2.830	4.000
	1.000	40	13,5	21	31	41	60	80	110	165	245	320	470	710	1.000	1.335	1.890	2.700
	750	30	10	15,5	23	31	45	60	82	125	185	240	350	535	750	1.000	1.420	2.025
28	1.500	54	18	28	43	56	80	110	145	225	325	425	625	910	1.280	1.740	2.500	3.500
	1.000	36	12	19	29	37	53	73	96	150	220	285	420	610	855	1.160	1.670	2.340
	750	27	9	14	21,5	28	40	55	72	112	165	215	315	460	640	870	1.250	1.755
31,5	1.500	48	16	25	38	49	70	95	125	200	290	400	570	830	1.200	1.600	2.200	3.200
	1.000	32	11	16	25	32	46	65	85	135	195	270	380	555	800	1.070	1.470	2.135
	750	24	8	12	18,5	24	34	49	64	100	145	200	285	420	600	800	1.100	1.600
35,5	1.500	42	15	22	34	46	60	85	120	180	275	355	515	770	1.080	1.420	2.100	3.000
	1.000	28	10	14,5	22,5	31	40	57	80	120	185	240	345	515	720	950	1.400	2.000
	750	21	7,5	10,5	16,5	23	30	43	60	90	140	180	260	390	540	715	1.050	1.500
40	1.500	38	14	20	30	43	56	80	110	155	235	310	465	680	970	1.300	1.900	2.650
	1.000	25	9,5	13	20	28,5	37	53	73	103	157	207	310	455	650	870	1.270	1.770
	750	19	7	9,7	15	21	28	40	55	77	118	155	232	342	490	652	952	1.328
45	1.500	33	12	18	26	36	50	70	97	145	215	280	410	610	870	1.150	1.725	2.400
	1.000	22	8	12	17	24	33	47	65	97	143	187	275	410	580	770	1.150	1.600
	750	17	6	9	12,7	18	25	35	49	73	107	140	206	307	435	578	862	1.200
50	1.500	30	10,5	15	22	30	45	62	85	130	195	245	360	560	760	1.020	1.520	2.120
	1.000	20	7	10	14,5	20	30	41	57	87	130	165	240	375	510	680	1.015	1.415
	750	15	5,5	7,5	11	15	22,5	31	43	65	97	125	180	281	382	510	762	1.062
56	1.500	27	9,5	14	20	28	41	55	78	112	170	215	315	490	690	910	1.350	1.900
	1.000	18	6,5	9	13	18,5	27	37	52	75	113	145	210	330	460	610	900	1.270
	750	13	5	6,7	9,7	14	20	28	39	56	85	110	157	248	345	460	675	952
63	1.500	24	8	12	17	24	37	49	65	105	145	200	285	430	620	810	1.200	1.700
	1.000	16	5,5	8	11	16	25	33	43	70	97	135	190	290	415	540	800	1.135
	750	12	4	6	8	12	19	25	32	52	73	100	142	218	311	405	600	852
71	1.500	21	7	10	15	21	32	42	58	90	135	175	255	390	550	730	1.070	1.500
	1.000	14	4,7	6,5	10	14	21	28	38	60	90	115	170	260	370	490	715	1.000
	750	10,5	3,5	4,8	7,5	10,5	16	21	28	45	67	86	127	195	280	370	536	750
80	1.500	18,7	6,5	9,5	14	18	30	37	52	82	120	160	230	350	480	645	950	1.300
	1.000	12,5	4,4	6	9	12	20	25	35	55	80	106	153	235	320	430	635	870
	750	9,3	3,2	4,5	6,7	9	15	19	26	41	60	80	115	176	240	322	476	652
90	1.500	16,7	6	8,5	12	17,5	26	33	47	75	108	140	205	310	450	605	850	1.200
	1.000	11,1	4	5,6	8	11,5	17	22	31	50	72	95	140	205	300	405	570	800
	750	8,3	3	4	6	8,5	13	16,5	23	37	54	72	105	154	225	305	430	600
100	1.500	15	5,5	7,5	10,5	16	25	29	43	61	87	120	180	260	370	550	710	1.000
	1.000	10	3,7	5	7	10,5	16,5	19	29	41	58	80	120	175	250	370	475	670
	750	7,5	2,8	3,7	5	7,5	12	14	22	31	43	60	90	131	188	280	356	502
112	1.500	13,4	5	6,5	9,5	14	21	27	40	59	85	115	165	245	350	480	680	950
	1.000	8,9	3,4	4	6	9	14	18	27	39	57	76	110	165	235	320	455	635
	750	6,7	2,5	3	4,5	6,5	10,5	13,5	20	29	43	57	82	124	176	240	342	476

Reductores con engrase a presión.
Variación máxima de la relación de transmisión $\pm 3\%$ (se pueden solicitar variaciones más restringidas).
A petición se consiguen relaciones de transmisión intermedias.

Gear units with forced lubrication.
Maximum variation for transmission ratio $\pm 3\%$. (More limited variations can be requested).
By request intermediate transmission ratios are obtained.

i_N	r. p. m. n_1	TAMAÑO REDUCTOR / GEAR UNIT SIZE															
		140	160	180	200	225	250	280	315	355	400	450	500	560	630	710	800
		Potencia límite térmica P_G en Kw. / Maximum thermal capacity P_G in Kw.															
		P_{G1} para reductores sin refrigeración / P_{G1} for gear units without cooling.															
22,4	1.500	32	42	55	72	90	105	135	175	220	265	340	415	515	645	800	1.000
	1.000	29	39	50	60	82	100	130	165	210	260	330	405	505	635	780	980
	750	24	32	46	57	75	92	120	155	202	245	310	390	495	620	760	960
56	1.500	28	37	48	62	83	100	130	165	210	260	330	410	500	630	780	980
	1.000	24	32	43	58	78	95	120	155	202	245	315	385	480	610	750	960
	750	21	28	38	50	70	87	115	142	195	220	295	365	470	600	735	940
		P_{G2} para reductores con refrigeración por ventilador / P_{G2} for gear units with fan cooling.															
22,4	1.500					135	165	215	272	335	420	525	655	810	1.000		
	1.000					120	150	192	245	310	385	480	595	745	935	1)	1)
	750					117	142	185	235	295	365	460	570	710	895		
56	1.500												635	785	980		
	1.000												570	715	890	1)	1)
	750												545	680	860		
		P_{G3} para reductores con refrigeración por serpentín / P_{G3} for gear units with coil cooling.															
22,4	1.500								330	380	530	650	730	830	1.150		
	1.000								315	370	520	640	720	820	950	1)	1)
	750								300	360	510	625	705	800	940		
		P_{G4} para reductores con refrigeración por ventilador y serpentín / P_{G4} for gear units with fan and coil cooling.															
22,4	1.500									500	700	835	970	1.120	1.330		
	1.000									470	650	795	910	1.060	1.250	1)	1)
	750									455	625	780	880	1.020	1.210		

(1) Refrigeración bajo consulta.

(1) Cooling on request.



REDUCTORES TIPO TT / TT TYPE GEAR UNITS

TRES TRENES DE ENGRANAJES - EJES PARALELOS
THREE STAGES - PARALLEL SHAFTS

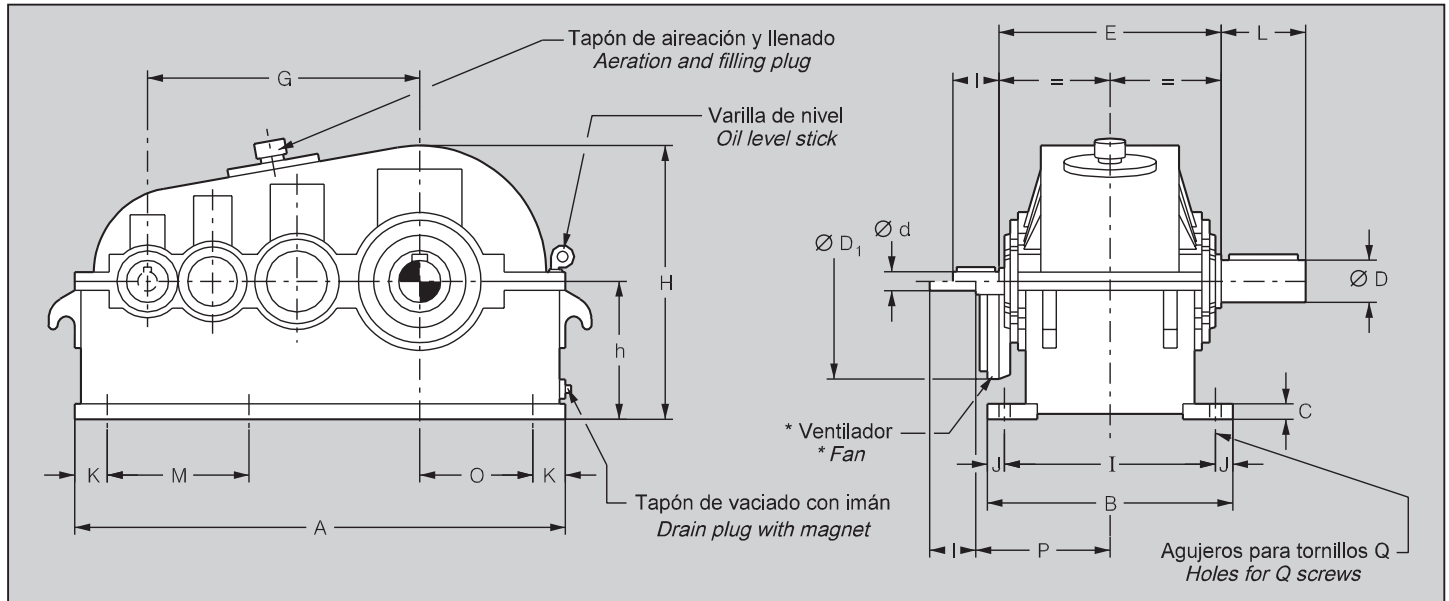

Extremos de árboles con chavetas DIN 6885 h1. Dimensiones: Pág 41.
Puntos de centrado con rosca forma D DIN 332. Dimensiones: Pág 41.
Tolerancia en extremos de árboles: Hasta Ø50 mm. ISO k6., superiores ISO m6.
* Situación orientativa. Si necesita ventilador se estudiará, en cada caso, la situación idónea.
1) Hasta 250 mm., tolerancia -0,5, superiores -1
2) Solamente para posición de trabajo B3.

Shafts ends with keys to DIN 6885 h1. Dimensions: page 41.
Centering points with thread to D DIN 332. Dimensions: page 41.
Tolerance of shaft ends: up to Ø50 mm. ISO k6, bigger ones ISO m6.
* Approximated situation. If fan is needed, the suitable situation will be studied in every case.
1) Up to 250 mm.. tolerance - 0.5, bigger ones -1.
2) Only for working position B3.
N= Number of holes of the base.

Tamaño Reductor Gear unit size	A	B	C	$i_N \leq 50$		$i_N > 50$		D	D_1	E	G	h ₁₎	H	I	J	K	L	M	N	O	P	Q	Peso = / Kg. Weight = / Kg.	Capacidad de aceite = / l. Quantity of oil = / l. 2)
				d	l	d	l																	
140	580	314	16	25	60	20	50	65	230	296	311	160	332	274	20	30	140	260	6	149	195	M16	129	8
160	646	358	18	30	80	20	50	75	230	340	352	180	367	318	20	35	140	288	6	162	217	M16	180	12
180	720	392	20	30	80	25	60	85	230	366	395	200	409	348	22	40	170	320	6	178	230	M18	270	16
200	807	422	22	35	80	25	60	95	300	380	440	225	454	372	25	45	170	239	8	192	250	M20	340	21
225	898	468	25	40	110	30	80	110	300	420	497	250	504	412	28	50	210	266	8	213	270	M22	450	28
250	1.004	526	28	45	110	35	80	120	340	472	555	280	565	466	30	55	210	298	8	237	306	M24	600	41
280	1.122	558	31	50	110	40	110	130	340	514	620	315	636	498	30	60	250	334	8	269	327	M24	770	58
315	1.244	620	34	55	110	45	110	150	410	576	700	355	703	560	30	70	250	276	10	288	371	M24	1.100	83
355	1.400	690	36	60	140	50	110	170	410	634	785	400	775	626	32	80	300	310	10	320	400	M27	1.460	123
400	1.572	726	40	65	140	50	110	190	500	666	880	450	872	662	32	90	350	348	10	357	433	M27	2.000	165
450	1.760	804	43	75	140	60	140	210	500	744	990	500	967	734	35	100	350	390	10	399	472	M30	2.800	230
500	1.952	878	45	85	170	65	140	230	700	822	1.105	560	1.078	808	35	110	410	433	10	443	540	M30	3.900	325
560	2.200	978	48	100	210	75	140	260	700	902	1.240	630	1.212	902	38	120	410	392	12	502	580	M33	5.230	474
630	2.495	1.076	55	110	210	85	170	300	850	980	1.395	710	1.380	986	45	135	470	445	12	575	635	M36	7.300	666
710	2.790	1.184	62	120	210	95	170	330	850	1.088	1.565	800	1.550	1.094	45	150	470	498	12	640	689	M39	9.600	952
800	3.135	1.322	70	130	250	110	210	370	950	1.202	1.760	900	1.745	1.222	50	170	550	559	12	715	756	M42	12.000	1.352

Posiciones de trabajo Working positions

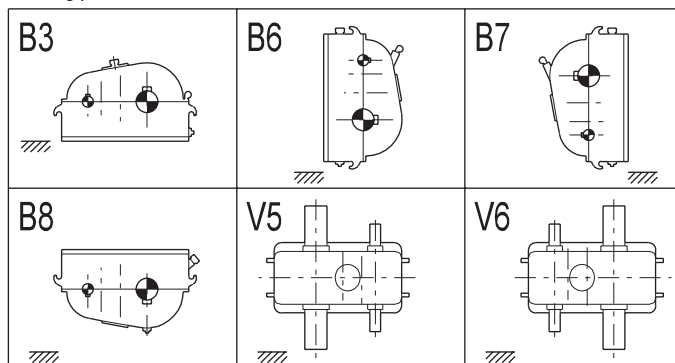

Posición extremos de árboles y Sentidos de giro Shafts position and direction of rotation

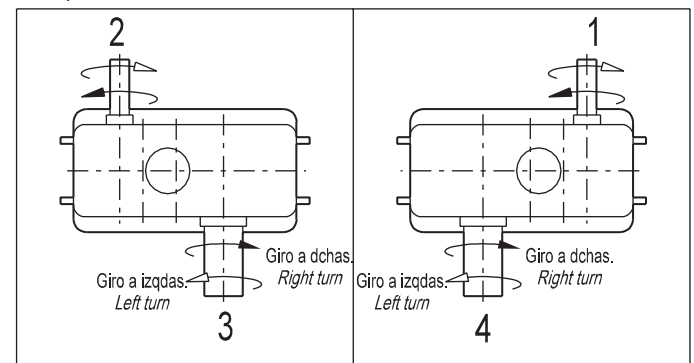

Equipamientos Técnicos Comerciales, S.A. se reserva el derecho de realizar cualquier modificación. / Equipamientos Técnicos Comerciales, S.A. reserves the right to modification.



REDUCTORES TIPO TTA / TTA TYPE GEAR UNITS

TRES TRENES DE ENGRANAJES - EJES PARALELOS - ARBOL LENTO HUECO
THREE STAGES - PARALLEL SHAFTS - HOLLOW SLOW SHAFT

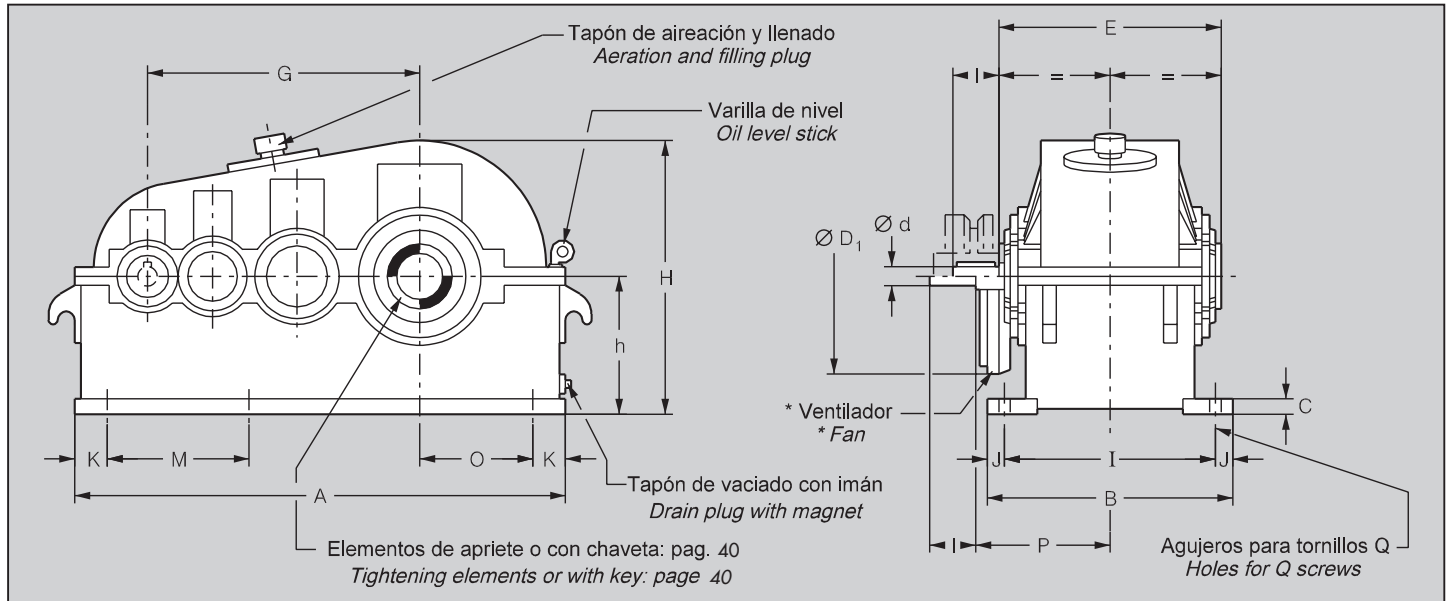

Extremos de árboles con chavetas DIN 6885 h1. Dimensiones: Pág 41.
 Puntos de centrado con rosca forma D DIN 332. Dimensiones: Pág 41.
 Tolerancia en extremos de árboles: Hasta Ø50 mm. ISO k6., superiores ISO m6.
 * Situación orientativa. Si necesita ventilador se estudiará, en cada caso, la situación idónea.
 1) Hasta 250 mm., tolerancia -0,5, superiores -1
 2) Solamente para posición de trabajo B3.

Shafts ends with keys to DIN 6885 h1. Dimensions: page 41.
 Centering points with thread to D DIN 332. Dimensions: page 41.
 Tolerance of shaft ends: up to Ø50 mm. ISO k6., bigger ones ISO m6.
 * Approximated situation. If fan is needed, the suitable situation will be studied in every case.
 1) Up to 250 mm., tolerance - 0.5, bigger ones -1.
 2) Only for working position B3.
 N= Number of holes of the base.

Tamaño Reductor Gear unit size	A	B	C	$i_N \leq 50$		$i_N > 50$		$\approx D_1$	E	G	h ₁₎	$\approx H$	I	J	K	M	N	O	P	Q	Peso = / Kg. Weight = / kg	Capacidad de aceite = / l. Quantity of oil = / l. 2)
				d	l	d	l															
140	580	314	16	25	60	20	50	230	296	311	160	332	274	20	30	260	6	149	195	M16	129	8
160	646	358	18	30	80	20	50	230	340	352	180	367	318	20	35	288	6	162	217	M16	180	12
180	720	392	20	30	80	25	60	230	366	395	200	409	348	22	40	320	6	178	230	M18	270	16
200	807	422	22	35	80	25	60	300	380	440	225	454	372	25	45	239	8	192	250	M20	340	21
225	898	468	25	40	110	30	80	300	420	497	250	504	412	28	50	266	8	213	270	M22	450	28
250	1.004	526	28	45	110	35	80	340	472	555	280	565	466	30	55	298	8	237	306	M24	600	41
280	1.122	558	31	50	110	40	110	340	514	620	315	636	498	30	60	334	8	269	327	M24	770	58
315	1.244	620	34	55	110	45	110	410	576	700	355	703	560	30	70	276	10	288	371	M24	1.100	83
355	1.400	690	36	60	140	50	110	410	634	785	400	775	626	32	80	310	10	320	400	M27	1.460	123
400	1.572	726	40	65	140	50	110	500	666	880	450	872	662	32	90	348	10	357	433	M27	2.000	165
450	1.760	804	43	75	140	60	140	500	744	990	500	967	734	35	100	390	10	399	472	M30	2.800	230
500	1.952	878	45	85	170	65	140	700	822	1.105	560	1.078	808	35	110	433	10	443	540	M30	3.900	325
560	2.200	978	48	100	210	75	140	700	902	1.240	630	1.212	902	38	120	392	12	502	580	M33	5.230	474
630	2.495	1.076	55	110	210	85	170	850	980	1.395	710	1.380	986	45	135	445	12	575	635	M36	7.300	666
710	2.790	1.184	62	120	210	95	170	850	1.088	1.565	800	1.550	1.094	45	150	498	12	640	689	M39	9.600	952
800	3.135	1.322	70	130	250	110	210	950	1.202	1.760	900	1.745	1.222	50	170	559	12	715	756	M42	12.000	1.352

Posiciones de trabajo / Working positions

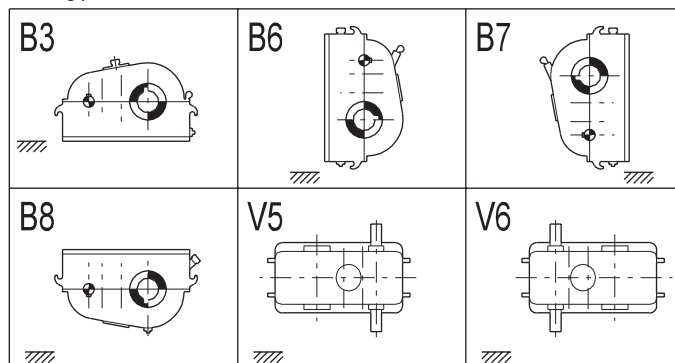

Posición extremos de árboles y Sentidos de giro / Shafts position and direction of rotation

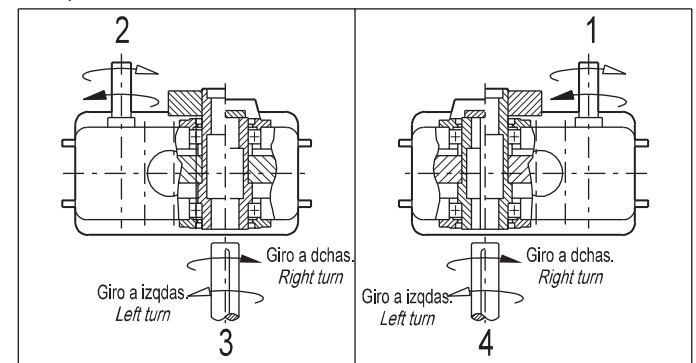

Equipamientos Técnicos Comerciales, S.A. se reserva el derecho de realizar cualquier modificación. / Equipamientos Técnicos Comerciales, S.A. reserves the right to modification.

REDUCTORES TIPO PTA / PTA TYPE GEAR UNITS

TRES TRENES DE ENGRANAJES - EJES PARALELOS - ARBOL LENTO HUECO
 THREE STAGES - PARALLEL SHAFTS - HOLLOW SLOW SHAFT

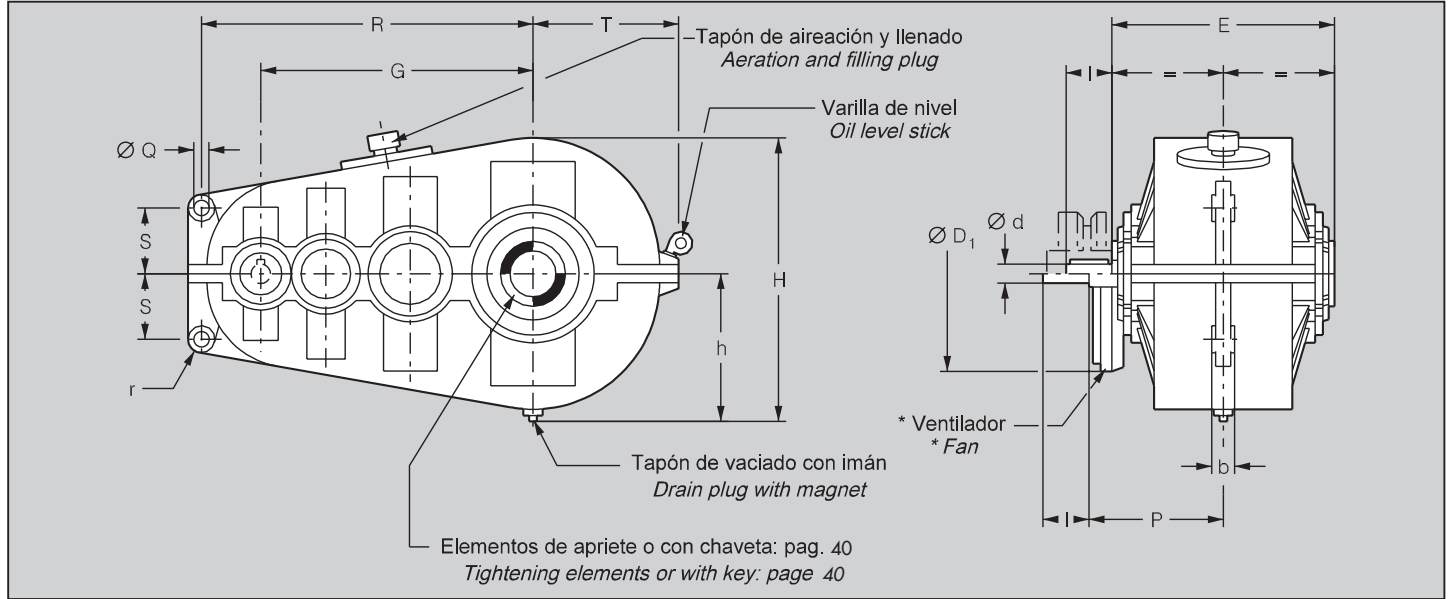

Extremos de árboles con chavetas DIN 6885 h1. Dimensiones: Pág 41.
 Puntos de centrado con rosca forma D DIN 332. Dimensiones: Pág 41.
 Tolerancia en extremos de árboles: Hasta Ø50 mm. ISO k6., superiores ISO m6.
 * Situación orientativa. Si necesita ventilador se estudiará, en cada caso, la situación idónea.
 1) Solamente para posición de trabajo B5.

Shafts ends with keys to DIN 6885 h1. Dimensions: page 41.
 Centering points with thread to D DIN 332. Dimensions: page 41.
 Tolerance of shaft ends: up to Ø50 mm. ISO k6., bigger ones ISO m6.
 * Approximated situation. If fan is needed, the suitable situation will be studied in every case.
 1) Only for working position B5.

Tamaño Reductor Gear unit size	b	$i_N \leq 50$		$i_N > 50$		$\approx D_1$	E	G	$\approx h$	H	P	Q	r	R	S	T	Peso = / Kg. Weight = / Kg.	Capacidad de aceite = / l. Quantity of oil = / l.
		d	l	d	l													
140	22	25	60	20	50	230	296	311	178	350	195	18	18	400	85	187	113	5,5
160	25	30	80	20	50	230	340	352	193	376	217	20	20	446	97	205	158	8
180	25	30	80	25	60	230	366	395	215	424	230	25	25	495	95	225	237	11,5
200	32	35	80	25	60	300	380	440	235	464	250	25	25	565	103	247	298	16
225	35	40	110	30	80	300	420	497	260	514	270	28	28	630	115	275	395	20
250	44	45	110	35	80	340	472	555	293	578	306	28	28	712	130	305	527	28
280	44	50	110	40	110	340	514	620	329	650	327	30	30	794	145	343	675	38
315	48	55	110	45	110	410	576	700	356	704	371	35	35	882	160	373	965	51
355	55	60	140	50	110	410	634	785	383	758	400	40	40	975	180	400	1.300	68
400	60	65	140	50	110	500	666	880	430	852	433	45	45	1.095	200	447	1.790	91
450	70	75	140	60	140	500	744	990	477	944	472	50	50	1.230	225	499	2.500	120
500	80	85	170	65	140	700	822	1.105	528	1.046	540	55	55	1.370	250	553	3.550	165
560	90	100	210	75	140	700	902	1.240	692	1.174	580	60	60	1.550	285	622	4.730	242
630	100	110	210	85	170	850	980	1.395	682	1.352	635	70	75	1.750	320	710	6.700	362
710	110	120	210	95	170	850	1.088	1.565	762	1.512	689	80	85	1.960	360	790	8.600	504
800	120	130	250	110	210	950	1.202	1.760	857	1.702	756	90	95	2.200	405	885	10.500	740

Posiciones de trabajo Working positions

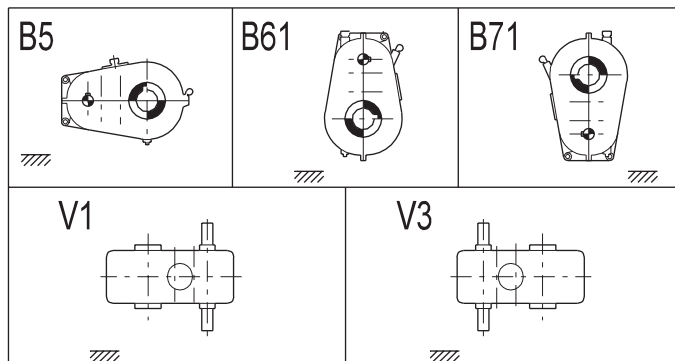

Posición extremos de árboles y Sentidos de giro Shafts position and direction of rotation

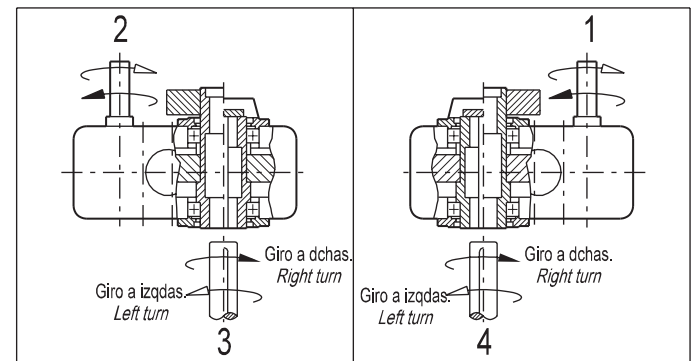

Equipamientos Técnicos Comerciales, S.A. se reserva el derecho de realizar cualquier modificación. / Equipamientos Técnicos Comerciales, S.A. reserves the right to modification.

REDUCTORES TIPO TTPV / TTPV TYPE GEAR UNITS

TRES TRENES DE ENGRANAJES - EJES PARALELOS
THREE STAGES - PARALLEL SHAFTS

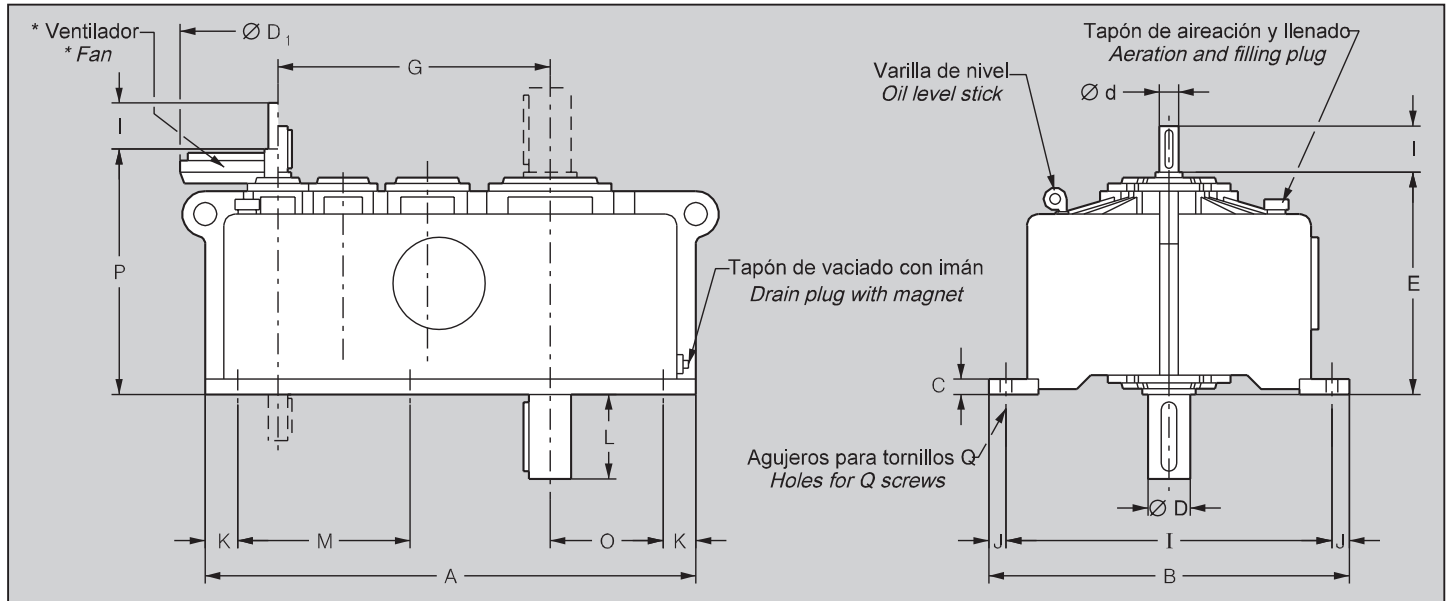

Extremos de árboles con chavetas DIN 6885 h1. Dimensiones: Pág 41.
Puntos de centrado con rosca forma D DIN 332. Dimensiones: Pág 41.
Tolerancia en extremos de árboles: Hasta Ø50 mm. ISO k6., superiores ISO m6.
* Situación orientativa. Si necesita ventilador se estudiará, en cada caso, la situación idónea.
1) Solamente para posición de trabajo V11 y V31.
N = Cantidad de agujeros en la base.

Shafts ends with keys to DIN 6885 h1. Dimensions: page 41.
Centering points with thread to D DIN 332. Dimensions: page 41.
Tolerance of shaft ends: up to Ø50 mm. ISO k6, bigger ones ISO m6.
* Approximated situation. If fan is needed, the suitable situation will be studied in every case.
1) Only for working position V11 y V31.
N= Number of holes of the base.

Tamaño Reductor Gear unit size	A	B	C	$i_N \leq 50$		$i_N > 50$		D	D_1	E	G	I	J	K	L	M	N	O	P	Q	Peso = / Kg. Weight = / kg	Capacidad de aceite = / l. Quantity of oil = / l.
				d	l	d	l															
140	580	420	16	25	60	20	50	65	230	296	311	380	20	30	140	260	6	149	343	M16	140	11
160	646	462	18	30	80	20	50	75	230	340	352	422	20	35	140	288	6	162	387	M16	195	17
180	720	510	20	30	80	25	60	85	230	366	395	466	22	40	170	320	6	178	413	M18	295	23
200	807	574	22	35	80	25	60	95	300	380	440	524	25	45	170	239	8	192	440	M20	370	31
225	898	630	25	40	110	30	80	110	300	420	497	574	28	50	210	266	8	213	480	M22	490	43
250	1.004	700	28	45	110	35	80	120	340	472	555	640	30	55	210	298	8	237	542	M24	650	60
280	1.122	758	31	50	110	40	110	130	340	514	620	698	30	60	250	334	8	269	584	M24	835	85
315	1.244	828	34	55	110	45	110	150	410	576	700	768	30	70	250	276	10	288	659	M24	1.190	117
355	1.400	914	36	60	140	50	110	170	410	634	785	850	32	80	300	310	10	320	717	M27	1.580	170
400	1.572	1.036	40	65	140	50	110	190	500	666	880	972	32	90	350	348	10	357	766	M27	2.170	237
450	1.760	1.136	43	75	140	60	140	210	500	744	990	1.066	35	100	350	390	10	399	844	M30	3.030	342
500	1.952	1.240	45	85	170	65	140	230	700	822	1.105	1.170	35	110	410	433	10	443	951	M30	4.200	440
560	2.200	1.404	48	100	210	75	140	260	700	902	1.240	1.328	38	120	410	392	12	502	1.031	M33	5.600	660
630	2.495	1.570	55	110	210	85	170	300	850	980	1.395	1.480	45	135	470	445	12	575	1.125	M36	7.700	940
710	2.790	1.716	62	120	210	95	170	330	850	1.088	1.565	1.626	45	150	470	498	12	640	1.233	M39	10.100	1.310
800	3.135	1.896	70	130	250	110	210	370	950	1.202	1.760	1.796	50	170	550	559	12	715	1.357	M42	12.600	1.840

Posiciones de trabajo
Working positions

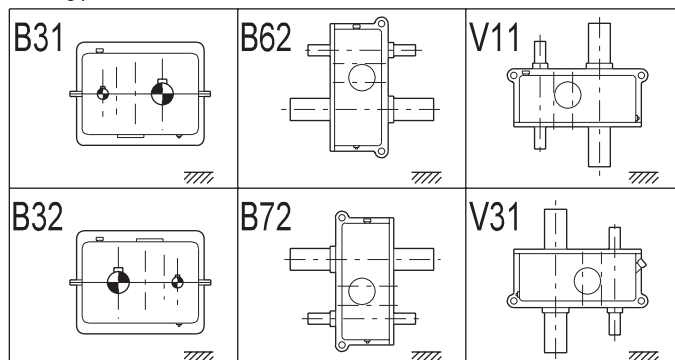

Posición extremos de árboles y Sentidos de giro
Shafts position and direction of rotation

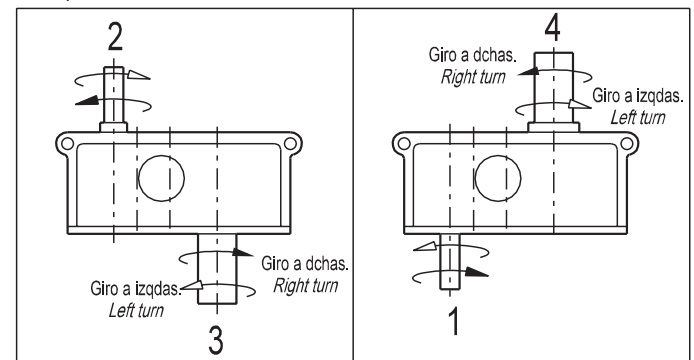

REDUCTORES TIPO TC-TCA-PCA-TCPV / TC-TCA-PCA-TCPV TYPE GEAR UNITS



CUATRO TRENES DE ENGRANAJES - EJES PARALELOS

FOUR STAGES - PARALLEL SHAFTS

Relación de transmis. i_N Transmission ratio	Velocidades r. p. m. Speeds		TAMAÑO REDUCTOR / GEAR UNIT SIZE															
	n_1	n_2	140	160	180	200	225	250	280	315	355	400	450	500	560	630	710	800
			Potencia P en Kw. / Power P in Kw.															
112	1.500	13,4	4	6	9	15	20	29	40	59	85	112	165	250	350	470	670	930
	1.000	8,9	2,7	4	6	10	13	19	26	39	56	75	110	170	235	315	445	620
	750	6,7	2	3	4,5	7,5	9,7	14	19,5	29	42	56	82	128	176	236	335	465
125	1.500	12	4	6	9	12	18,5	26	35	50	78	102	145	225	310	425	590	850
	1.000	8	2,7	4	6	8	12	17	23	33	52	68	96	150	206	285	395	570
	750	6	2	3	4,5	6	9	12,5	17	25	39	51	72	112	155	215	300	430
140	1.500	10,7	3,5	5,6	8,3	11	16,5	22,5	32	45	70	90	130	200	280	375	530	750
	1.000	7,1	2,4	3,7	5,5	7,3	11	15	21	30	46	60	86	135	190	250	355	500
	750	5,4	1,8	2,7	4	5,5	8,2	11	15,5	22,5	34	45	64	102	142	190	266	375
160	1.500	9,4	3,1	5,4	7,5	9,5	14	20	28	40	60	80	115	178	250	335	480	680
	1.000	6,3	2	3,6	5	6,3	9	13,3	18,5	26	40	53	76	120	170	225	320	455
	750	4,7	1,6	2,7	3,7	4,7	6,7	10	14	19,5	30	40	57	90	130	170	240	342
180	1.500	8,3	2,8	5,4	6,5	8,2	13	19	25	36	55	70	102	155	220	300	430	620
	1.000	5,6	1,9	3,6	4,3	5,5	8,5	12,5	16,5	24	37	47	68	105	146	200	290	415
	750	4,2	1,4	2,7	3,2	4	6,3	9	12	18	28	35	51	78	110	150	218	312
200	1.500	7,5	2,5	5	5,5	7,5	12	15,5	22	32	50	63	92	142	200	270	385	545
	1.000	5	1,7	3,3	3,5	5	8	10	14,5	21	33	42	62	95	135	180	260	365
	750	3,8	1,3	2,4	2,5	3,75	6	7,5	11	15,5	25	31	46	72	102	135	195	275
225	1.500	6,6	2,2	4,1	4,6	6,5	10	14	20	29	45	57	80	125	180	240	350	500
	1.000	4,4	1,5	2,7	3	4,2	6,5	9,3	13	19	30	38	53	83	120	160	233	335
	750	3,3	1,1	2	2,2	3	4,8	7	9,5	14	22	28	40	62	90	120	175	252
250	1.500	6	2	3,3	4,3	6	9	12,5	17	26	40	50	71	112	160	215	310	435
	1.000	4	1,3	2,2	2,8	4	6	8,3	11	17	27	33	47	75	106	145	206	290
	750	3	1	1,6	1,8	3	4,5	6	8	12,5	20	25	35	56	80	110	155	217
280	1.500	5,4	1,8	3,3	3,9	5,3	8	11	15,5	22	35	45	65	100	140	190	270	385
	1.000	3,6	1,2	2,2	2,6	3,5	5,3	7,3	10	14,5	23	30	43	67	95	126	180	260
	750	2,7	0,9	1,6	1,9	2,6	4	5,5	7,5	11	17	22	32	50	71	95	135	195
315	1.500	4,8	1,6	3,3	3,5	4,5	7,5	9,5	13	20	31	42	57	90	125	170	240	345
	1.000	3,2	1	2,2	2,3	3	5	6,3	8,5	13	20	28	38	60	85	115	160	230
	750	2,4	0,8	1,6	2	2,2	3,75	4,7	6	9,5	15	21	28	45	64	86	120	172
355	1.500	4,2	1,4	2,8	2,8	4	6,5	8,5	12	18	28	37	50	80	112	150	220	310
	1.000	2,8	0,9	1,8	1,9	2,6	4,3	5,5	8	12	19	25	33	53	75	100	146	206
	750	2,1	0,7	1,3	1,4	1,9	3,2	4	6	9	14	19	25	40	56	75	110	155
400	1.500	3,8	1,3	2,3	2,5	3,5	6	8	11	16	25	32	45	70	100	132	190	265
	1.000	2,5	0,8	1,5	1,6	2,3	4	5	7,3	10,5	16	21	30	46	66	88	126	180
	750	1,9	0,6	1,1	1,2	1,7	3	3,7	5,5	8	12	16	22	34	50	66	95	135
450	1.500	3,3	1,3	2,3	2,3	3,2	5	7	10	13,5	21	28	40	62	90	122	172	235
	1.000	2,2	0,8	1,5	1,6	2,1	3,3	4,5	6,5	9	14	18	26	41	60	81	115	156
	750	1,7	0,6	1,1	1,2	1,5	2,4	3,3	4,8	6,5	10,5	13,5	19	31	45	61	86	117
500	1.500	3	1	1,9	2	2,7	4,2	6,2	9	12	18	25	36	58	82	110	150	215
	1.000	2	0,7	1,2	1,3	1,8	2,8	4	6	8	12	16	24	40	55	73	100	145
	750	1,5	0,5	0,9	0,9	1,3	2	3	4,5	6	9	12	18	30	41	55	75	110
560	1.500	2,7	0,9	1,7	1,8	2,3	3,7	5	7,5	11	15,5	21	32	48	65	92	130	190
	1.000	1,8	0,6	1,1	1,2	1,5	2,4	3,3	5	7,3	10	14	21	32	43	62	86	126
	750	1,3	0,4	0,8	0,9	1,1	1,8	2,5	3,7	5,5	7,5	10,5	16	24	32	46	64	94
630	1.500	2,4	0,8	1,5	1,6	2	3,2	4,5	6,5	9	13	20	28	45	60	84	115	165
	1.000	1,6	0,5	1	1	1,3	2,1	3	4,3	6	8,5	13	18	30	40	56	76	110
	750	1,2	0,4	0,75	0,75	0,9	1,5	2,2	3	4,5	6	9,5	13,5	22,5	30	42	57	82

Variación máxima de la relación de transmisión $\pm 3\%$ (se pueden solicitar variaciones más restringidas).
A petición se consiguen relaciones de transmisión intermedias.

Maximum variation for transmission ratio $\pm 3\%$. (More limited variations can be requested).
By request intermediate transmission ratios are obtained.

i_N	r. p. m. n_1	TAMAÑO REDUCTOR / GEAR UNIT SIZE															
		140	160	180	200	225	250	280	315	355	400	450	500	560	630	710	800
Potencia límite térmica P_G en Kw. / Maximum thermal capacity P_G in Kw.																	
P_{G1} para reductores sin refrigeración / P_{G1} for gear units without cooling.																	
112 a 630	1.500	13	18	25	32	41	52	60	80	100	125	172	220	280	350	420	540
	1.000	10	15	22,5	28,5	37	46	55	72	92	118	160	205	260	330	410	520
	750	6	10	21	26,5	34	40	50	68	85	110	152	190	240	300	390	500

Equipamientos Técnicos Comerciales, S.A. se reserva el derecho de realizar cualquier modificación. / Equipamientos Técnicos Comerciales, S.A. reserves the right to modification.

REDUCTORES TIPO TC / TC TYPE GEAR UNITS

CUATRO TRENES DE ENGRANAJES - EJES PARALELOS
FOUR STAGES - PARALLEL SHAFTS

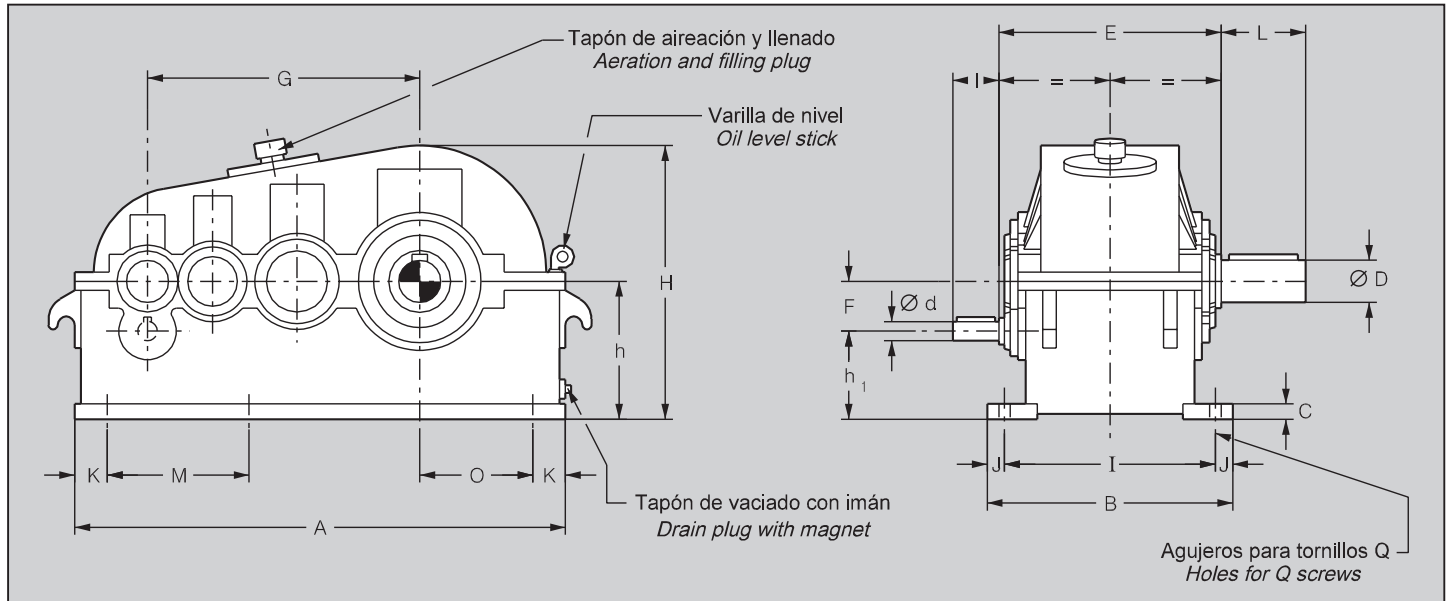

Extremos de árboles con chavetas DIN 6885 h1. Dimensiones: Pág 41.
Puntos de centrado con rosca forma D DIN 332. Dimensiones: Pág 41.
Tolerancia en extremos de árboles: Hasta Ø50 mm. ISO k6., superiores ISO m6.
1) Hasta 250 mm., tolerancia -0,5, superiores -1
2) Solamente para posición de trabajo B3.

Shafts ends with keys to DIN 6885 h1. Dimensions: page 41.
Centering points with thread to D DIN 332. Dimensions: page 41.
Tolerance of shaft ends: up to Ø50 mm. ISO k6, bigger ones ISO m6.
1) Up to 250 mm.. tolerance - 0.5, bigger ones -1.
2) Only for working position B3.
N= Number of holes of the base.

Tamaño Reductor Gear unit size	A	B	C	d	D	E	F	G	h ₁	h ₁	H	I	J	K	L	M	N	O	Q	Peso = / Kg. Weight = / Kg.	Capacidad de aceite = / l. Quantity of oil = / l. 2)	
140	580	314	16	14	65	296	56	311	104	160	332	274	20	30	30	140	260	6	149	M16	130	8,5
160	646	358	18	16	75	340	63	352	117	180	367	318	20	35	40	140	288	6	162	M16	182	13
180	720	392	20	20	85	366	71	395	129	200	409	348	22	40	50	170	320	6	178	M18	272	17
200	807	422	22	20	95	380	80	440	145	225	454	372	25	45	50	170	239	8	192	M20	345	22
225	898	468	25	25	110	420	90	497	160	250	504	412	28	50	60	210	266	8	213	M22	455	30
250	1.004	526	28	25	120	472	100	555	180	280	565	466	30	55	60	210	298	8	237	M24	605	44
280	1.122	558	31	30	130	514	112	620	203	315	636	498	30	60	80	250	334	8	269	M24	780	62
315	1.244	620	34	35	150	576	125	700	230	355	703	560	30	70	80	250	276	10	288	M24	1.120	89
355	1.400	690	36	40	170	634	140	785	260	400	775	626	32	80	110	300	310	10	320	M27	1.490	132
400	1.572	726	40	40	190	666	160	880	290	450	872	662	32	90	110	350	348	10	357	M27	2.040	177
450	1.760	804	43	45	210	744	180	990	320	500	967	734	35	100	110	350	390	10	399	M30	2.855	247
500	1.952	878	45	55	230	822	200	1.105	360	560	1.078	808	35	110	110	410	433	10	444	M30	3.970	350
560	2.200	978	48	60	260	902	225	1.240	405	630	1.212	902	38	120	140	410	392	12	502	M33	5.320	510
630	2.495	1.076	55	70	300	980	250	1.395	460	710	1.380	986	45	135	140	470	445	12	575	M36	7.410	715
710	2.790	1.184	62	75	330	1.088	280	1.565	520	800	1.550	1.094	45	150	140	470	498	12	640	M39	9.760	1.020
800	3.135	1.322	70	80	370	1.202	315	1.760	585	900	1.745	1.222	50	170	170	550	559	12	715	M42	12.200	1.450

Posiciones de trabajo Working positions

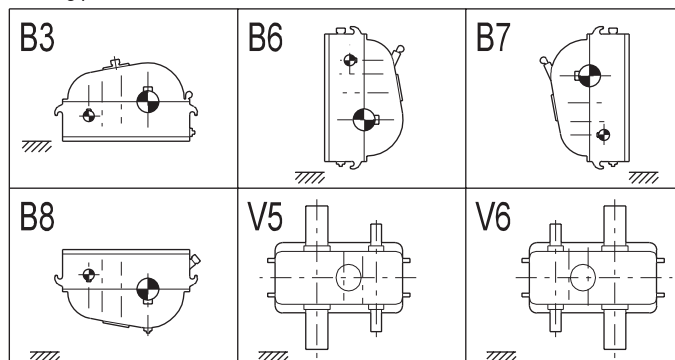

Posición extremos de árboles y Sentidos de giro Shafts position and direction of rotation

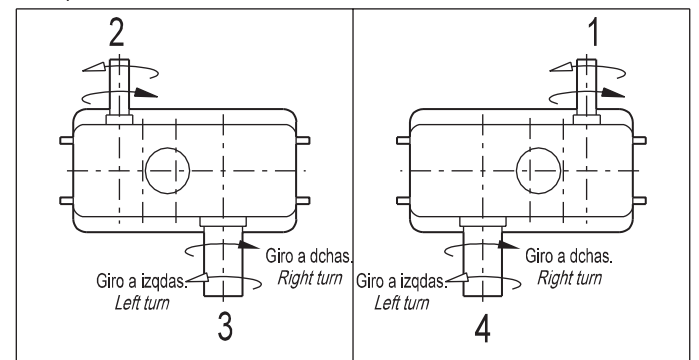

Equipamientos Técnicos Comerciales, S.A. se reserva el derecho de realizar cualquier modificación. / Equipamientos Técnicos Comerciales, S.A. reserves the right to modification.

REDUCTORES TIPO TCA / TCA TYPE GEAR UNITS

CUATRO TRENES DE ENGRANAJES - EJES PARALELOS - ARBOL LENTO HUECO
 FOUR STAGES - PARALLEL SHAFTS - HOLLOW SLOW SHAFT

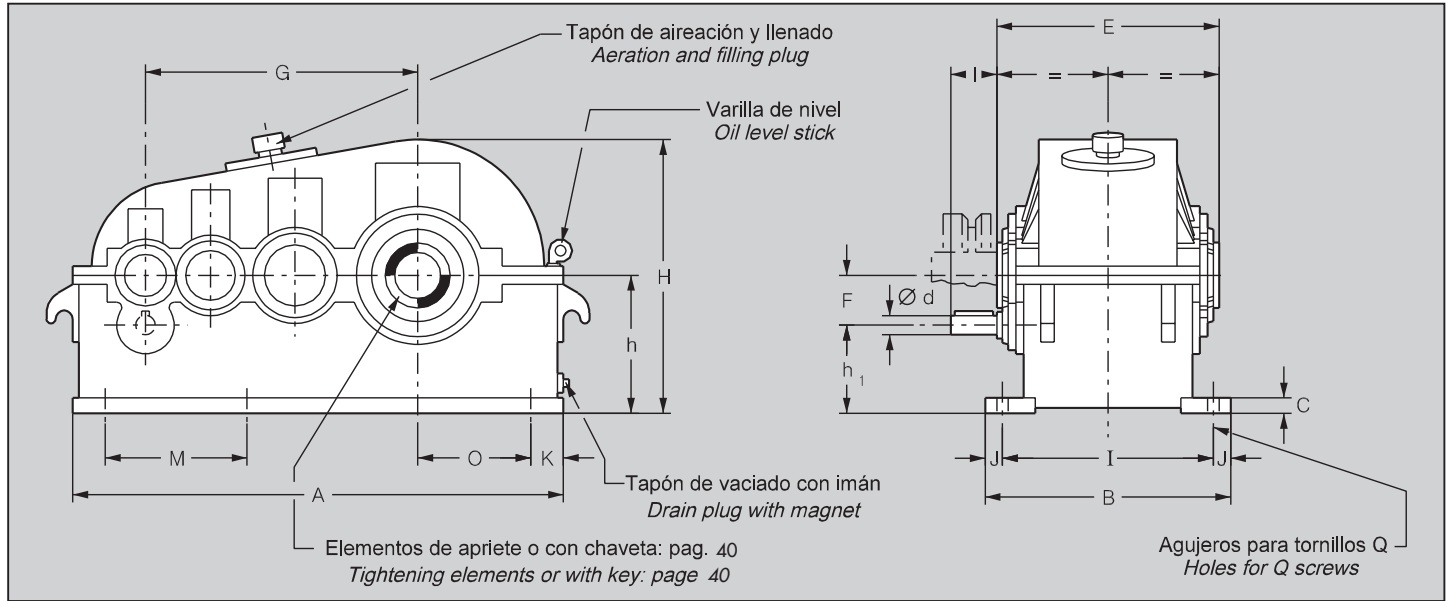

Extremos de árboles con chavetas DIN 6885 h1. Dimensiones: Pág 41.
 Puntos de centrado con rosca forma D DIN 332. Dimensiones: Pág 41.
 Tolerancia en extremos de árboles: Hasta Ø50 mm. ISO k6., superiores ISO m6.
 1) Hasta 250 mm., tolerancia -0,5, superiores -1
 2) Solamente para posición de trabajo B3.
 N = Cantidad de agujeros en la base.

Shafts ends with keys to DIN 6885 h1. Dimensions: page 41.
 Centering points with thread to D DIN 332. Dimensions: page 41.
 Tolerance of shaft ends: up to Ø50 mm. ISO k6, bigger ones ISO m6.
 1) Up to 250 mm.. tolerance - 0.5, bigger ones -1.
 2) Only for working position B3.
 N= Number of holes of the base.

Tamaño Reductor Gear unit size	A	B	C	d	E	F	G	h ₁	h ₁)	H	I	J	K	I	M	N	O	Q	Peso = / Kg. Weight = / Kg	Capacidad de aceite = / l. Quantity of oil = / l. 2)
140	580	314	16	14	296	56	311	104	160	332	274	20	30	30	260	6	149	M16	130	8,5
160	646	358	18	16	340	63	352	117	180	367	318	20	35	40	288	6	162	M16	182	13
180	720	392	20	20	366	71	395	129	200	409	348	22	40	50	320	6	178	M18	272	17
200	807	422	22	20	380	80	440	145	225	454	372	25	45	50	239	8	192	M20	345	22
225	898	468	25	25	420	90	497	160	250	504	412	28	50	60	266	8	213	M22	455	30
250	1.004	526	28	25	472	100	555	180	280	565	466	30	55	60	298	8	237	M24	605	44
280	1.122	558	31	30	514	112	620	203	315	636	498	30	60	80	334	8	269	M24	780	62
315	1.244	620	34	35	576	125	700	230	355	703	560	30	70	80	276	10	288	M24	1.120	89
355	1.400	690	36	40	634	140	785	260	400	775	626	32	80	110	310	10	320	M27	1.490	132
400	1.572	726	40	40	666	160	880	290	450	872	662	32	90	110	348	10	357	M27	2.040	177
450	1.760	804	43	45	744	180	990	320	500	967	734	35	100	110	390	10	399	M30	2.855	247
500	1.952	878	45	55	822	200	1.105	360	560	1.078	808	35	110	110	433	10	444	M30	3.970	350
560	2.200	978	48	60	902	225	1.240	405	630	1.212	902	38	120	140	392	12	502	M33	5.320	510
630	2.495	1.076	55	70	980	250	1.395	460	710	1.380	986	45	135	140	445	12	575	M36	7.410	715
710	2.790	1.184	62	75	1.088	280	1.565	520	800	1.550	1.094	45	150	140	498	12	640	M39	9.760	1.020
800	3.135	1.322	70	80	1.202	315	1.760	585	900	1.745	1.222	50	170	170	559	12	715	M42	12.200	1.450

Posiciones de trabajo
Working positions

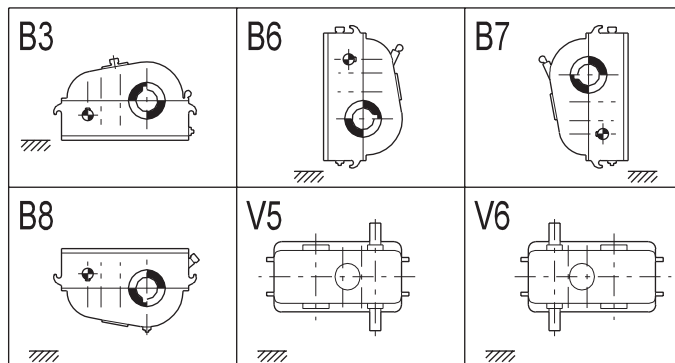

Posición extremos de árboles y Sentidos de giro
Shafts position and direction of rotation

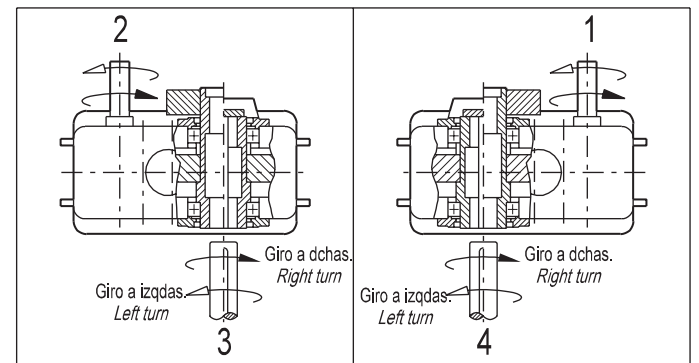

Equipamientos Técnicos Comerciales, S.A. se reserva el derecho de realizar cualquier modificación. / Equipamientos Técnicos Comerciales, S.A. reserves the right to modification.

REDUCTORES TIPO PCA / PCA TYPE GEAR UNITS

CUATRO TRENES DE ENGRANAJES - EJES PARALELOS - ARBOL LENTO HUECO
 FOUR STAGES - PARALLEL SHAFTS - HOLLOW SLOW SHAFT

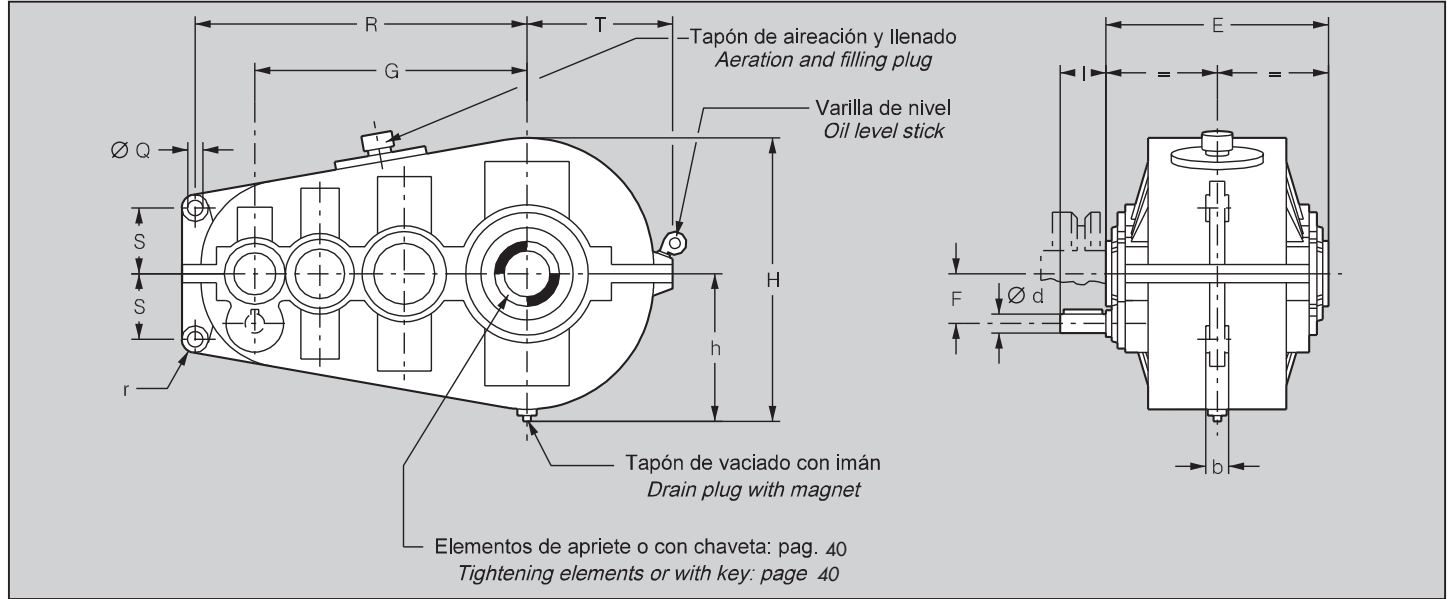

Extremos de árboles con chavetas DIN 6885 h1. Dimensiones: Pág 41.
 Puntos de centrado con rosca forma D DIN 332. Dimensiones: Pág 41.
 Tolerancia en extremos de árboles: Hasta Ø50 mm. ISO k6., superiores ISO m6.
 1) Solamente para posición de trabajo B5.

Shafts ends with keys to DIN 6885 h1. Dimensions: page 41.
 Centering points with thread to D DIN 332. Dimensions: page 41.
 Tolerance of shaft ends: up to Ø50 mm. ISO k6., bigger ones ISO m6.
 1) Only for working position B5.

Tamaño Reductor Gear unit size	b	d	E	F	G	h	H	I	Q	r	R	S	T	Peso = / Kg. Weight = / Kg	Capacidad de aceite = / l. Quantity of oil = / l. 1)
140	22	14	296	56	311	178	350	30	18	18	400	85	187	114	6
160	25	16	340	63	352	193	376	40	20	20	446	97	205	160	8,5
180	25	20	366	71	395	215	424	50	25	25	495	95	225	240	12
200	32	20	380	80	440	235	464	50	25	25	565	103	247	305	17
225	35	25	420	90	497	260	514	60	28	28	630	115	275	400	22
250	44	25	472	100	555	293	578	60	28	28	712	130	305	532	30
280	44	30	514	112	620	329	650	80	30	30	794	145	343	685	41
315	48	35	576	125	700	356	704	80	35	35	882	160	373	985	54
355	55	40	634	140	785	383	758	110	40	40	975	180	400	1.330	72
400	60	40	666	160	880	430	852	110	45	45	1.095	200	447	1.825	97
450	70	45	744	180	990	477	944	110	50	50	1.230	225	499	2.560	128
500	80	55	822	200	1.105	528	1.046	110	55	55	1.370	250	553	3.620	175
560	90	60	902	225	1.240	692	1.174	140	60	60	1.550	285	622	4.820	257
630	100	70	980	250	1.395	682	1.352	140	70	75	1.750	320	710	6.810	385
710	110	75	1.088	280	1.565	762	1.512	140	80	85	1.960	360	790	8.760	535
800	120	80	1.202	315	1.760	857	1.702	170	90	95	2.200	405	885	10.700	785

Posiciones de trabajo
Working positions

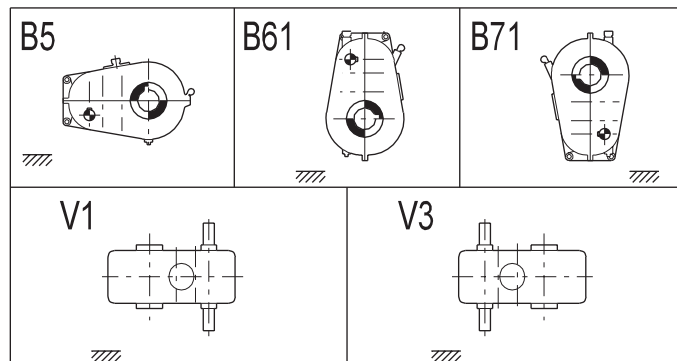

Posición extremos de árboles y Sentidos de giro
Shafts position and direction of rotation

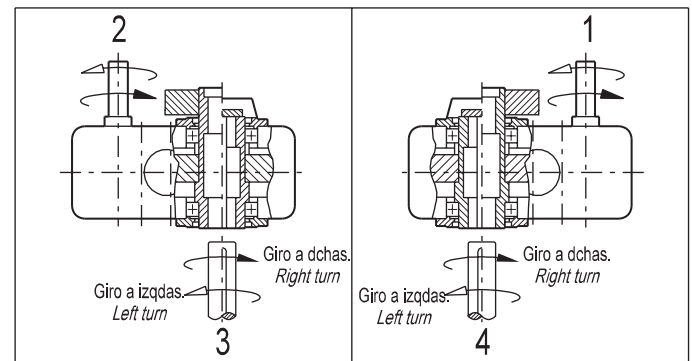

Equipamientos Técnicos Comerciales, S.A. se reserva el derecho de realizar cualquier modificación. / Equipamientos Técnicos Comerciales, S.A. reserves the right to modification.

REDUCTORES TIPO TCPV / TCPV TYPE GEAR UNITS

CUATRO TRENES DE ENGRANAJES - EJES PARALELOS
FOUR STAGES - PARALLEL SHAFTS

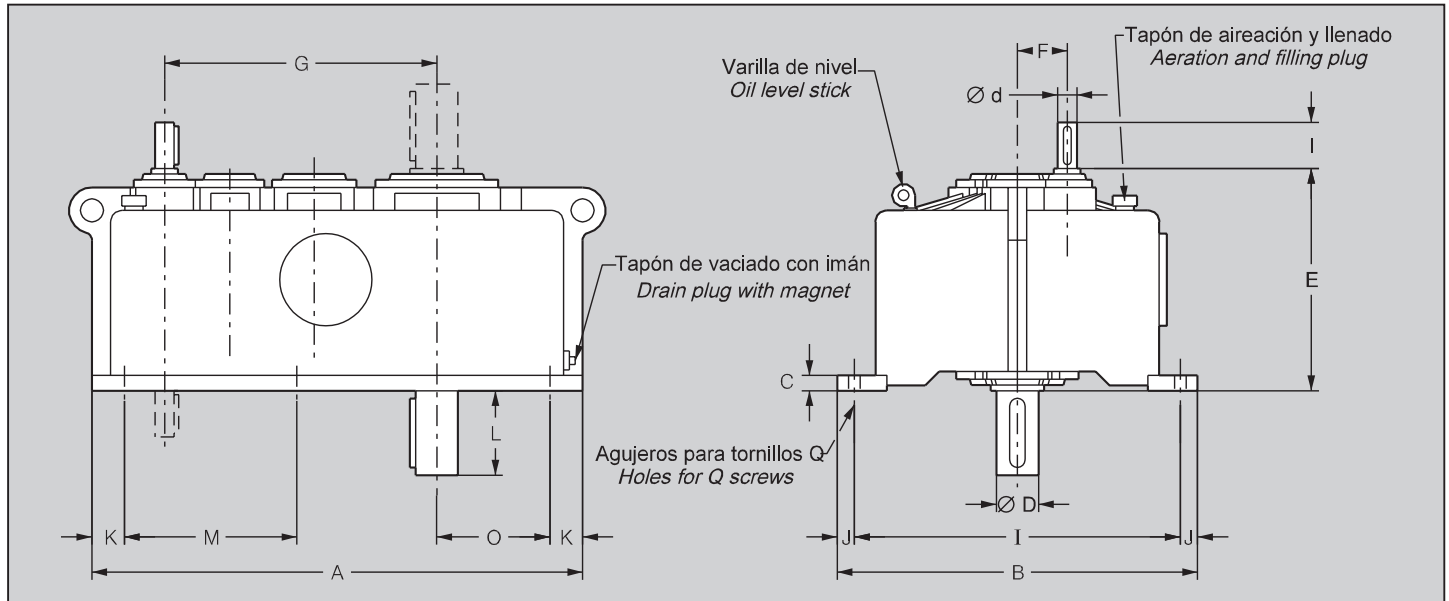

Extremos de árboles con chavetas DIN 6885 h1. Dimensiones: Pág 41.
Puntos de centrado con rosca forma D DIN 332. Dimensiones: Pág 41.
Tolerancia en extremos de árboles: Hasta Ø50 mm. ISO k6., superiores ISO m6.
1) Solamente para posición de trabajo V11 y V31.
N = Cantidad de agujeros en la base.

Shafts ends with keys to DIN 6885 h1. Dimensions: page 41.
Centering points with thread to D DIN 332. Dimensions: page 41.
Tolerance of shaft ends: up to Ø50 mm. ISO k6, bigger ones ISO m6.
1) Only for working position V11 y V31.
N= Number of holes of the base.

Tamaño Reductor Gear unit size	A	B	C	d	D	E	F	G	I	J	K	L	M	N	O	Q	Peso = / Kg. Weight = / Kg	Capacidad de aceite = / l. Quantity of oil = / l.	
140	580	420	16	14	65	296	56	311	380	20	30	30	140	260	6	149	M16	141	11
160	646	462	18	16	75	340	63	352	422	20	35	40	140	288	6	162	M16	197	17
180	720	510	20	20	85	366	71	395	466	22	40	50	170	320	6	178	M18	297	23
200	807	574	22	20	95	380	80	440	524	25	45	50	170	239	8	192	M20	375	31
225	898	630	25	25	110	420	90	497	574	28	50	60	210	266	8	213	M22	495	43
250	1.004	700	28	25	120	472	100	555	640	30	55	60	210	298	8	237	M24	655	60
280	1.122	758	31	30	130	514	112	620	698	30	60	80	250	334	8	269	M24	845	85
315	1.244	828	34	35	150	576	125	700	768	30	70	80	250	276	10	288	M24	1.210	117
355	1.400	914	36	40	170	634	140	785	850	32	80	110	300	310	10	320	M27	1.610	170
400	1.572	1.036	40	40	190	666	160	880	972	32	90	110	350	348	10	357	M27	2.210	237
450	1.760	1.136	43	45	210	744	180	990	1.066	35	100	110	350	390	10	399	M30	3.085	342
500	1.952	1.240	45	55	230	822	200	1.105	1.170	35	110	110	410	433	10	443	M30	4.270	440
560	2.200	1.404	48	60	260	902	225	1.240	1.328	38	120	140	410	392	12	502	M33	5.690	660
630	2.495	1.570	55	70	300	980	250	1.395	1.480	45	135	140	470	445	12	575	M36	7.810	940
710	2.790	1.716	62	75	330	1.088	280	1.565	1.626	45	150	140	470	498	12	640	M39	10.260	1.310
800	3.135	1.896	70	80	370	1.202	315	1.760	1.796	50	170	170	550	559	12	715	M42	12.800	1.840

Posiciones de trabajo
Working positions

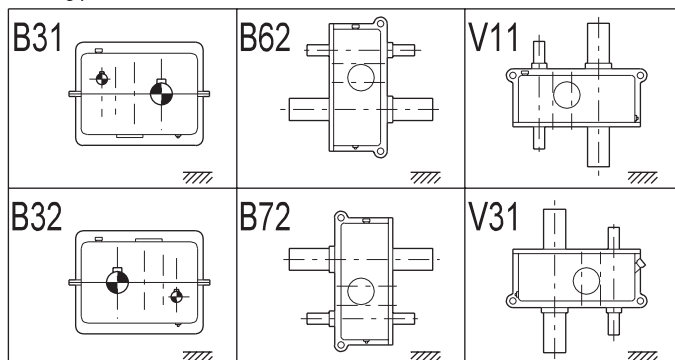

Posición extremos de árboles y Sentidos de giro
Shafts position and direction of rotation

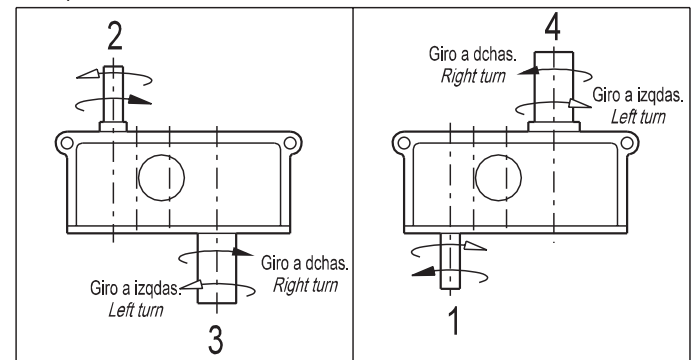

Equipamientos Técnicos Comerciales, S.A. se reserva el derecho de realizar cualquier modificación. / Equipamientos Técnicos Comerciales, S.A. reserves the right to modification.



REDUCTORES TIPO TDH-TDHA-PDHA-TDHSV / TDH-TDHA-PDHA-TDHSV TYPE GEAR UNITS



DOS TRENES DE ENGRANAJES - EJES PERPENDICULARES
TWO STAGES - PERPENDICULAR SHAFTS

Relación de transm. i_N Transmission ratio	Velocidades r. p. m. Speeds		TAMAÑO REDUCTOR / GEAR UNIT SIZE														
	n_1	n_2	112	125	140	160	180	200	225	250	280	315	355	400	450	500	560
	Potencia P_N en Kw. / Power P_N in Kw.																
6,3	1.500	240	34	46	65	95	120	172	245	360	460	610	845	1.275	1.825	2.225	2.520
	1.000	160	25	34	47	70	84	126	175	270	340	470	635	950	1.360	1.740	2.230
	750	120	18	25	36	54	70	103	140	210	270	375	495	770	1.050	1.340	1.570
7,1	1.500	210	32	45	65	95	120	172	245	360	460	610	845	1.275	1.825	2.225	2.520
	1.000	140	24	32	47	70	84	126	175	270	340	470	635	950	1.360	1.740	2.230
	750	106	17	24	36	54	70	103	140	210	270	375	495	770	1.050	1.340	1.570
8	1.500	185	29	42	62	92	112	168	230	330	450	600	780	1.155	1.720	2.150	2.250
	1.000	125	23	29	45	70	85	125	175	250	340	460	595	880	1.315	1.640	1.795
	750	94	15	23	33	52	62	92	130	185	255	345	445	660	986	1.230	1.345
9	1.500	167	26	37	55	75	100	140	190	290	400	540	680	1.030	1.580	2.025	2.150
	1.000	111	20	25,5	42	55	75	105	145	220	305	412	520	786	1.210	1.545	1.640
	750	83	14	20	31	41	56	80	108	165	230	310	390	590	910	1.160	1.230
10	1.500	150	23	33	45	68	95	130	175	255	350	475	630	925	1.400	1.900	2.080
	1.000	100	17	23	34	50	70	100	133	195	267	362	480	706	1.070	1.450	1.590
	750	75	12	17	25	37	52	75	100	145	200	270	360	530	802	1.090	1.190
11,2	1.500	134	20	29	40	59	82	120	150	232	325	450	570	845	1.200	1.550	2.000
	1.000	89	15	20	30	45	60	90	115	177	248	343	435	645	916	1.185	1.530
	750	67	11	15	22	34	45	67	86	132	186	257	325	485	687	888	1.150
12,5	1.500	120	18	26	35	53	70	105	135	210	290	370	505	725	950	1.350	1.650
	1.000	80	13	18	26	40	53	80	103	160	220	282	385	555	725	1.030	1.260
	750	60	10	14	19,5	30	39	60	77	120	165	212	290	416	545	772	945
14	1.500	107	16,5	23	32	48	65	82	125	175	260	345	470	610	820	1.100	1.250
	1.000	71	12	16	24	36	50	62	95	133	198	265	360	465	626	840	955
	750	54	9	12	18	27	37,5	46	71	100	148	200	270	350	470	630	716
16	1.500	94	12,5	17	24	36	52	62	105	145	210	275	400	500	640	900	1.050
	1.000	62	9,5	13	18	27	40	47	80	110	160	210	305	382	490	690	802
	750	47	7	10	13,5	20	30	35	60	82	120	157	230	286	368	517	600
18	1.500	83	9,5	13	18	26	40	50	70	100	150	210	360	450	580	750	900
	1.000	55	6,5	10	13	20	30	38	53	76	115	160	275	345	445	570	690
	750	41	5	7	9,7	15	22,5	28,5	40	57	86	120	206	258	334	428	517

Reductores con engrase a presión.
Variación máxima de la relación de transmisión $\pm 3\%$ (se pueden solicitar variaciones más restringidas).
A petición se consiguen relaciones de transmisión intermedias.

Gear units with forced lubrication.
Maximum variation for transmission ratio $\pm 3\%$. (More limited variations can be requested).
By request intermediate transmission ratios are obtained.

i_N	r. p. m. n_1	TAMAÑO REDUCTOR / GEAR UNIT SIZE														
		112	125	140	160	180	200	225	250	280	315	355	400	450	500	560
Potencia límite térmica P_G en Kw. / Maximum thermal capacity P_G in Kw.																
P_{G1} para reductores sin refrigeración / P_{G1} for gear units without cooling.																
6,3	1.500	28	34	40	48	64	85	110	130	160	215	260	330	400	520	670
	1.000	25	31	37	45	60	80	105	125	155	210	250	320	390	510	660
	750	22	28	34	42	55	75	102	120	145	200	245	310	385	500	650
10	1.500	21	28	36	47	60	80	107	128	155	210	250	320	390	510	660
	1.000	18	25	32	43	53	78	100	123	145	205	245	310	385	500	650
	750	16	23	30	38	50	73	97	118	135	200	240	305	380	490	640
P_{G2} para reductores con refrigeración por ventilador / P_{G2} for gear units with fan cooling.																
6,3	1.500	60	74	90	110	130	185	240	300	370	480	580	750	900	1.100	1.450
	1.000	55	67	82	100	120	172	220	275	345	400	500	710	850	1.000	1.280
	750	48	59	72	95	110	158	190	250	310	385	450	680	810	935	1.210
10	1.500	55	70	85	100	110	170	200	280	350	445	570	740	880	1.050	1.300
	1.000	49	62	75	95	100	150	185	260	310	415	510	700	810	980	1.050
	750	43	54	65	88	92	135	168	245	290	390	480	680	750	890	980
P_{G3} para reductores con refrigeración por serpentín / P_{G3} for gear units with coil cooling.																
≤ 18	1.500							285	315	360	400	450	650	750	850	1.000
	1.000							272	305	350	380	440	640	710	830	980
	750							265	300	330	370	420	630	680	815	950
P_{G4} para reductores con refrigeración por ventilador y serpentín / P_{G4} for gear units with fan and coil cooling.																
≤ 18	1.500								485	565	670	780	1.100	1.300	1.500	1.800
	1.000								440	520	620	730	1.040	1.150	1.340	1.700
	750								410	480	560	680	920	1.100	1.270	1.600

REDUCTORES TIPO TDH / TDH TYPE GEAR UNITS

DOS TRENES DE ENGRANAJES - EJES PERPENDICULARES
TWO STAGES - PERPENDICULAR SHAFTS

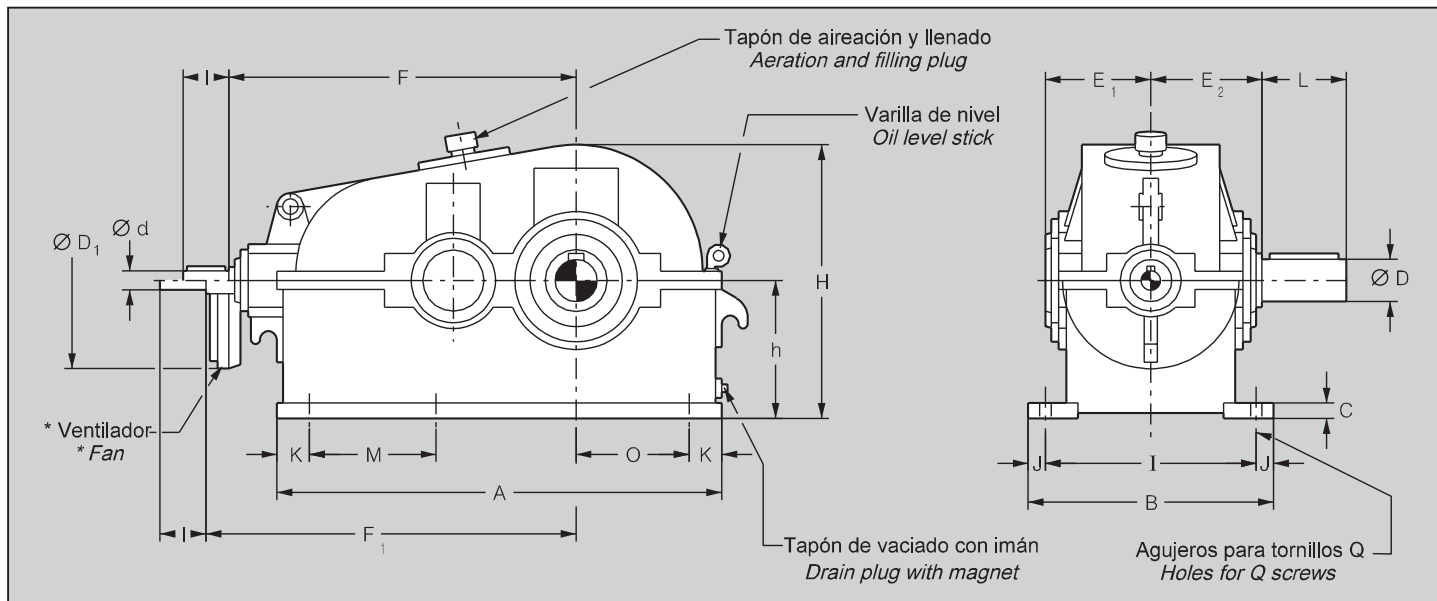

Extremos de árboles con chavetas DIN 6885 h1. Dimensiones: Pág 41.
Puntos de centrado con rosca forma D DIN 332. Dimensiones: Pág 41.
Tolerancia en extremos de árboles: Hasta Ø50 mm. ISO k6., superiores ISO m6.
* Situación orientativa. Si necesita ventilador se estudiará, en cada caso, la situación idónea.
1) Hasta 250 mm., tolerancia -0,5, superiores -1
2) Solamente para posición de trabajo B3.

Shafts ends with keys to DIN 6885 h1. Dimensions: page 41.
Centering points with thread to D DIN 332. Dimensions: page 41.
Tolerance of shaft ends: up to Ø50 mm. ISO k6, bigger ones ISO m6.
* Approximated situation. If fan is needed, the suitable situation will be studied in every case.
1) Up to 250 mm.. tolerance - 0.5, bigger ones -1.
2) Only for working position B3.
N= Number of holes of the base.

Tamaño Reductor Gear unit size	A	B	C	$i_N < 11,2$		$i_N \geq 11,2$		D	D_1	E_1	E_2	F	F_1	h_{11}	H	I	J	K	L	M	N	O	Q	Peso = / Kg. Weight = / Kg.	Capacidad de aceite = / l. Quantity of oil = / l. 2)
				d	l	d	l																		
112	418	252	14	30	80	25	60	55	180	107	123	354	401	125	262	220	16	24	110	185	6	122	M12	76	2,5
125	462	280	15	35	80	30	80	60	230	117	133	392	452	140	292	244	18	26	120	205	6	134	M14	100	4
140	516	314	16	40	110	35	80	65	230	130	148	445	505	160	332	274	20	30	140	228	6	149	M16	140	5,5
160	570	358	18	45	110	40	110	75	300	152	170	490	560	180	367	318	20	35	140	250	6	162	M16	200	8
180	640	392	20	50	110	45	110	85	340	165	183	547	630	200	409	348	22	40	170	280	6	178	M18	280	12
200	714	422	22	50	110	45	110	95	340	172	190	605	688	225	454	372	25	45	170	312	6	192	M20	380	16
225	802	468	25	55	110	50	110	110	410	192	210	671	800	250	504	412	28	50	210	234	8	213	M22	510	22
250	896	526	28	60	140	50	110	120	410	216	236	755	884	280	565	466	30	55	210	262	8	237	M24	640	32
280	1.002	558	31	65	140	60	140	130	500	237	257	845	990	315	636	498	30	60	250	294	8	269	M24	840	44
315	1.106	620	34	80	170	65	140	150	500	268	288	944	1.089	355	703	560	30	70	250	322	8	288	M24	1.150	58
355	1.240	690	36	90	170	70	140	170	500	297	317	1.042	1.187	400	775	626	32	80	300	270	10	320	M27	1.570	92
400	1.396	726	40	100	210	80	170	190	500	313	333	1.173	1.318	450	872	662	32	90	350	304	10	357	M27	2.110	124
450	1.564	804	43	110	210	95	170	210	700	340	372	1.326	1.471	500	967	734	35	100	350	341	10	399	M30	2.950	175
500	1.736	878	45	120	210	100	210	230	700	379	411	1.478	1.623	560	1.078	808	35	110	410	379	10	443	M30	4.070	245
560	1.950	978	48	130	250	110	210	260	850	419	451	1.658	1.803	630	1.212	902	38	120	410	342	12	502	M33	5.500	350

Posiciones de trabajo Working positions

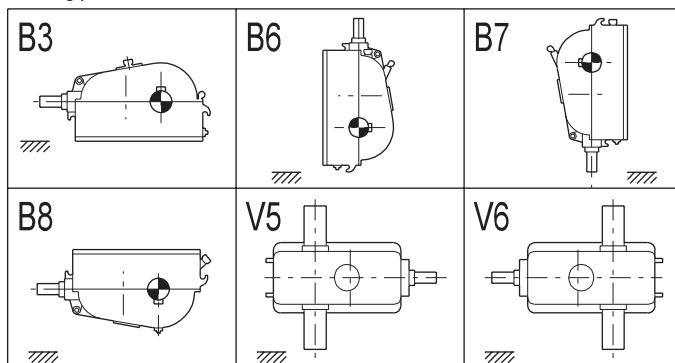

Posición extremos de árboles y Sentidos de giro Shafts position and direction of rotation

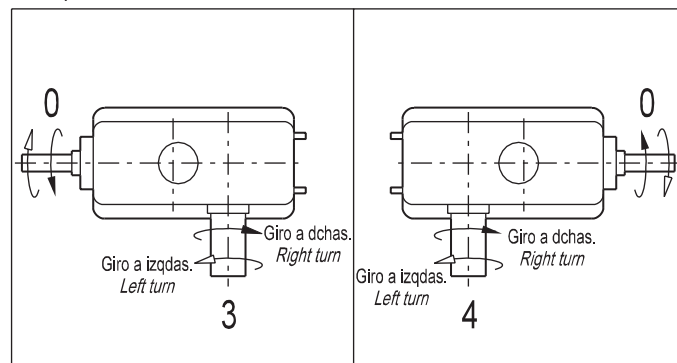

Equipamientos Técnicos Comerciales, S.A. se reserva el derecho de realizar cualquier modificación. / Equipamientos Técnicos Comerciales, S.A. reserves the right to modification.

REDUCTORES TIPO TDHA / TDHA TYPE GEAR UNITS

DOS TRENES DE ENGRANAJES - EJES PERPENDICULARES - ARBOL LENTO HUECO
TWO STAGES - PERPENDICULAR SHAFTS - HOLLOW SLOW SHAFT

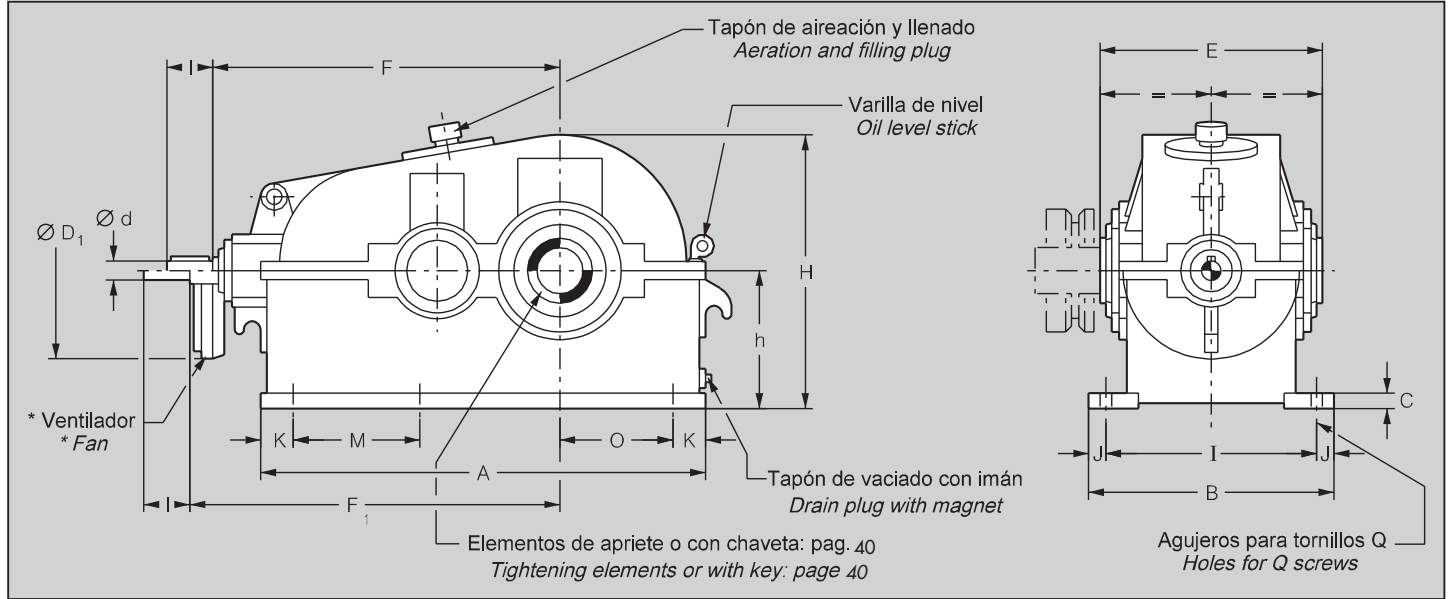

Extremos de árboles con chavetas DIN 6885 h1. Dimensiones: Pág 41.
Puntos de centrado con rosca forma D DIN 332. Dimensiones: Pág 41.
Tolerancia en extremos de árboles: Hasta Ø50 mm. ISO k6., superiores ISO m6.
* Situación orientativa. Si necesita ventilador se estudiará, en cada caso, la situación idónea.
1) Hasta 250 mm., tolerancia -0,5, superiores -1
2) Solamente para posición de trabajo B3.

Shafts ends with keys to DIN 6885 h1. Dimensions: page 41.
Centering points with thread to D DIN 332. Dimensions: page 41.
Tolerance of shaft ends: up to Ø50 mm. ISO k6., bigger ones ISO m6.
* Approximated situation. If fan is needed, the suitable situation will be studied in every case.
1) Up to 250 mm., tolerance - 0.5, bigger ones - 1.
2) Only for working position B3.
N = Number of holes of the base.

Tamaño Reductor Gear unit size	A	B	C	$i_N < 11,2$		$i_N \geq 11,2$		$\approx D_1$	E	F	F ₁	h ₁₎	$\approx H$	I	J	K	M	N	O	Q	Peso = / Kg Weight = / Kg	Capacidad de aceite = / l. Quantity of oil = / l.
				d	l	d	l															
112	418	252	14	30	80	25	60	180	246	354	401	125	262	220	16	24	185	6	122	M12	76	2,5
125	462	280	15	35	80	30	80	230	266	392	452	140	292	244	18	26	205	6	134	M14	100	4
140	516	314	16	40	110	35	80	230	296	445	505	160	332	274	20	30	228	6	149	M16	140	5,5
160	570	358	18	45	110	40	110	300	340	490	560	180	367	318	20	35	250	6	162	M16	200	8
180	640	392	20	50	110	45	110	340	366	547	630	200	409	348	22	40	280	6	178	M18	280	12
200	714	422	22	50	110	45	110	340	380	605	688	225	454	372	25	45	312	6	192	M20	380	16
225	802	468	25	55	110	50	110	410	420	671	800	250	504	412	28	50	234	8	213	M22	510	22
250	896	526	28	60	140	50	110	410	472	755	884	280	565	466	30	55	262	8	237	M24	640	32
280	1.002	558	31	65	140	60	140	500	514	845	990	315	636	498	30	60	294	8	269	M24	840	44
315	1.106	620	34	80	170	65	140	500	576	944	1.089	355	703	560	30	70	322	8	288	M24	1.150	58
355	1.240	690	36	90	170	70	140	500	634	1.042	1.187	400	775	626	32	80	270	10	320	M27	1.570	92
400	1.396	726	40	100	210	80	170	500	666	1.173	1.318	450	872	662	32	90	304	10	357	M27	2.110	124
450	1.564	804	43	110	210	95	170	700	744	1.326	1.471	500	967	734	35	100	341	10	399	M30	2.950	175
500	1.736	878	45	120	210	100	210	700	822	1.478	1.623	560	1.078	808	35	110	379	10	443	M30	4.070	245
560	1.950	978	48	130	250	110	210	850	902	1.658	1.803	630	1.212	902	38	120	342	12	502	M33	5.500	350

Posiciones de trabajo Working positions

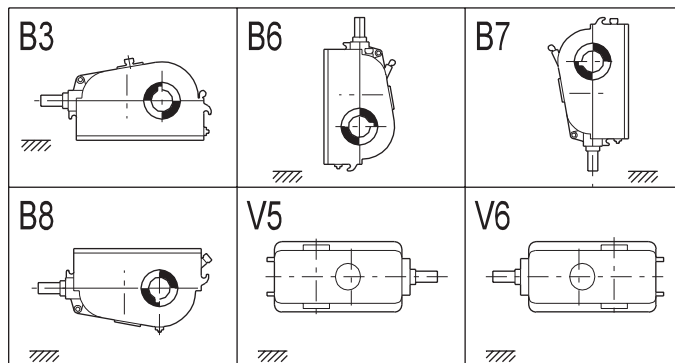

Posición extremos de árboles y Sentidos de giro Shafts position and direction of rotation

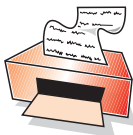
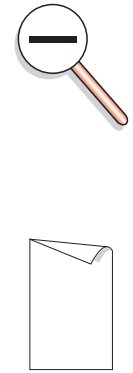
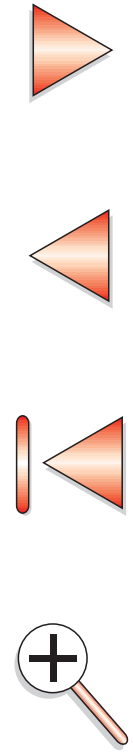
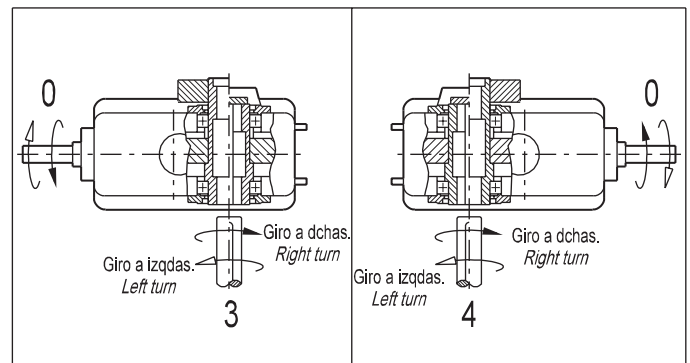

REDUCTORES TIPO PDHA / PDHA TYPE GEAR UNITS



DOS TRENES DE ENGRANAJES - EJES PERPENDICULARES - ARBOL LENTO HUECO
TWO STAGES - PERPENDICULAR SHAFTS - HOLLOW SLOW SHAFT

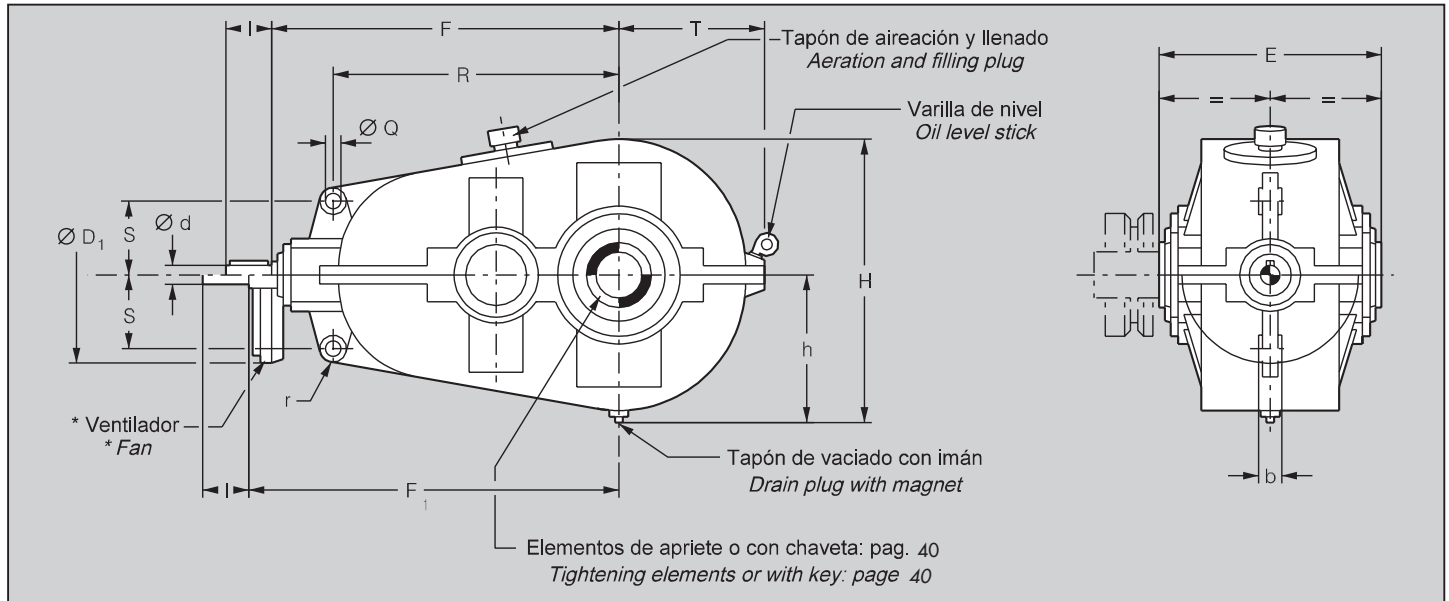

Extremos de árboles con chavetas DIN 6885 h1. Dimensiones: Pág 41.

Puntos de centrado con rosca forma D DIN 332. Dimensiones: Pág 41.

Tolerancia en extremos de árboles: Hasta Ø50 mm. ISO k6., superiores ISO m6.

* Situación orientativa. Si necesita ventilador se estudiará, en cada caso, la situación idónea.

1) Solamente para posición de trabajo B5.

Shafts ends with keys to DIN 6885 h1. Dimensions: page 41.

Centering points with thread to D DIN 332. Dimensions: page 41.

Tolerance of shaft ends: up to Ø50 mm. ISO k6, bigger ones ISO m6.

* Approximated situation. If fan is needed, the suitable situation will be studied in every case.

1) Only for working position B5.

Tamaño Reductor Gear unit size	b	$i_N < 11,2$		$i_N \geq 11,2$		D_1	E	F	F_1	h	H	Q	r	R	S	T	Peso = / Kg Weight = / Kg	Capacidad de aceite = / l. Quantity of oil = / l. 1)
		d	l	d	l													
112	18	30	80	25	60	180	246	354	401	143	280	16	16	266	80	153	71	0,8
125	20	35	80	30	80	230	266	392	452	158	310	18	18	291	90	167	93	1,4
140	22	40	110	35	80	230	296	445	505	178	350	18	18	327	95	187	130	2
160	25	45	110	40	110	300	340	490	560	193	376	20	20	361	105	205	180	3
180	28	50	110	45	110	340	366	547	630	215	424	25	25	404	120	225	246	4
200	32	50	110	45	110	340	380	605	688	235	464	25	25	463	130	247	322	6
225	35	55	110	50	110	410	420	671	800	260	514	28	28	523	145	275	438	9
250	44	60	140	50	110	410	472	755	884	293	578	28	28	591	165	305	563	12
280	44	65	140	60	140	500	514	845	990	329	650	30	30	657	185	343	750	15
315	48	80	170	65	140	500	576	944	1.089	356	704	35	35	728	200	373	1.040	17
355	55	90	170	70	140	500	634	1.042	1.187	383	758	40	40	800	210	400	1.430	30
400	60	100	210	80	170	500	666	1.173	1.318	430	852	45	45	904	235	447	1.900	46
450	70	110	210	95	170	700	744	1.326	1.471	477	944	50	50	1.015	250	499	2.640	60
500	80	120	210	100	210	700	822	1.478	1.623	528	1.046	55	55	1.128	285	553	3.710	85
560	90	130	250	110	210	850	902	1.658	1.803	592	1.174	60	60	1.268	330	622	4.750	125

Posiciones de trabajo
Working positions

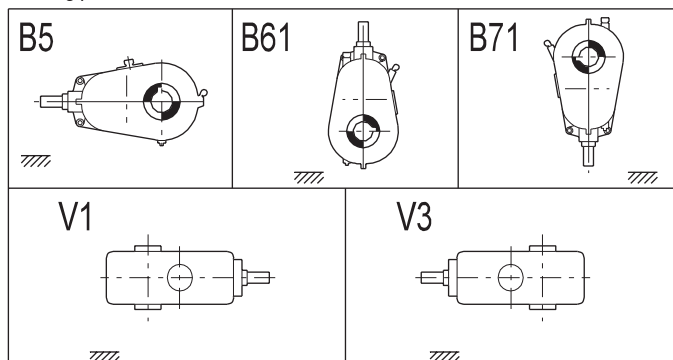

Posición extremos de árboles y Sentidos de giro
Shafts position and direction of rotation

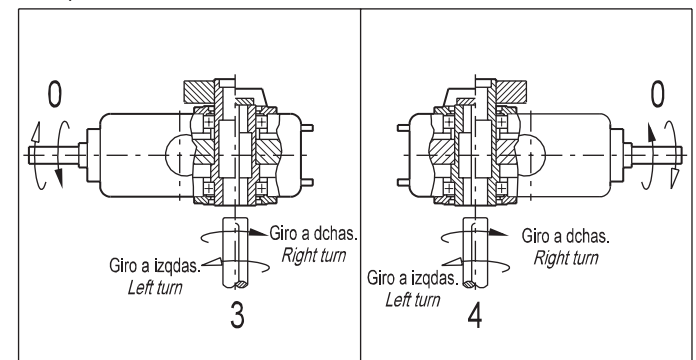

Equipamientos Técnicos Comerciales, S.A. se reserva el derecho de realizar cualquier modificación. / Equipamientos Técnicos Comerciales, S.A. reserves the right to modification.

REDUCTORES TIPO TDHV / TDHV TYPE GEAR UNITS



DOS TRENES DE ENGRANAJES - EJES PERPENDICULARES
TWO STAGES - PERPENDICULAR SHAFTS

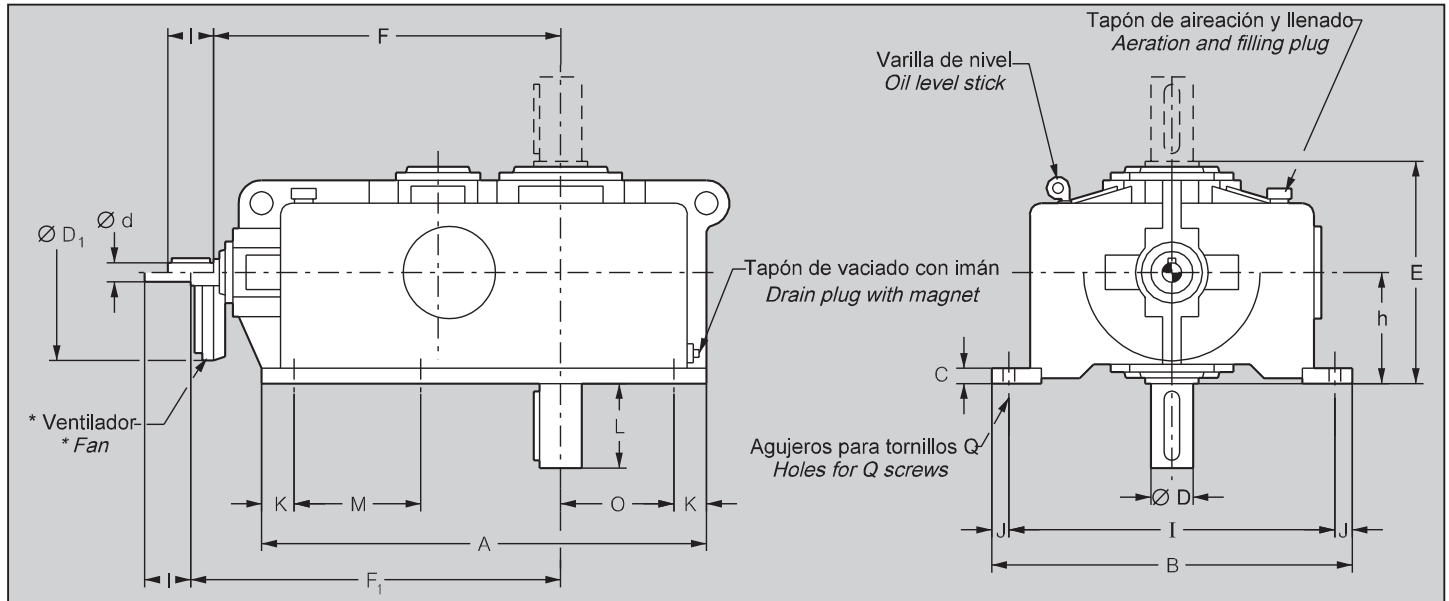

Extremos de árboles con chavetas DIN 6885 h1. Dimensiones: Pág 41.
Puntos de centrado con rosca forma D DIN 332. Dimensiones: Pág 41.
Tolerancia en extremos de árboles: Hasta Ø50 mm. ISO k6., superiores ISO m6.
* Situación orientativa. Si necesita ventilador se estudiará, en cada caso, la situación idónea.
1) Hasta 250 mm., tolerancia -0,5, superiores -1
2) Solamente para posición de trabajo V11 y V31.
N = Cantidad de agujeros en la base.

Shafts ends with keys to DIN 6885 h1. Dimensions: page 41.
Centering points with thread to D DIN 332. Dimensions: page 41.
Tolerance of shaft ends: up to Ø50 mm. ISO k6, bigger ones ISO m6.
* Approximated situation. If fan is needed, the suitable situation will be studied in every case.
1) Up to 250 mm.. tolerance - 0.5, bigger ones -1.
2) Only for working position V11 y V31.
N= Number of holes of the base.

Tamaño Reductor Gear unit size	A	B	C	$i_N < 11,2$		$i_N \geq 11,2$		D	$\approx D_1$	E	F	F_1	h ₁₎	I	J	K	L	M	N	O	Q	Peso = / Kg Weight = / Kg	Capacidad de aceite = / l. Quantity of oil = / l. 2)
				d	l	d	l																
112	418	336	14	30	80	25	60	55	180	246	354	401	123	304	16	24	110	185	6	122	M12	82	4,5
125	462	376	15	35	80	30	80	60	230	266	392	452	133	340	18	26	120	205	6	134	M14	105	6,5
140	516	420	16	40	110	35	80	65	230	296	445	505	148	380	20	30	140	228	6	149	M16	150	8
160	570	462	18	45	110	40	110	75	300	340	490	560	170	422	20	35	140	250	6	162	M16	213	13
180	640	510	20	50	110	45	110	85	340	366	547	630	183	466	22	40	170	280	6	178	M18	300	17
200	714	574	22	50	110	45	110	95	340	380	605	688	190	524	25	45	170	312	6	192	M20	408	23
225	802	630	25	55	110	50	110	110	410	420	671	800	210	574	28	50	210	234	8	213	M22	540	34
250	896	700	28	60	140	50	110	120	410	472	755	884	236	640	30	55	210	262	8	237	M24	690	48
280	1.002	758	31	65	140	60	140	130	500	514	845	990	257	698	30	60	250	294	8	269	M24	890	68
315	1.106	828	34	80	170	65	140	150	500	576	944	1.089	288	768	30	70	250	322	8	288	M24	1.220	92
355	1.240	914	36	90	170	70	140	170	500	634	1.042	1.187	317	850	32	80	300	270	10	320	M27	1.680	130
400	1.396	1.036	40	100	210	80	170	190	500	666	1.173	1.318	333	972	32	90	350	304	10	357	M27	2.250	180
450	1.564	1.136	43	110	210	95	170	210	700	744	1.326	1.471	372	1.066	35	100	350	341	10	399	M30	3.100	260
500	1.736	1.240	45	120	210	100	210	230	700	822	1.478	1.623	411	1.170	35	110	410	379	10	443	M30	4.300	335
560	1.950	1.404	48	130	250	110	210	260	850	902	1.658	1.803	451	1.328	38	120	410	342	12	502	M33	5.800	415

Posiciones de trabajo
Working positions

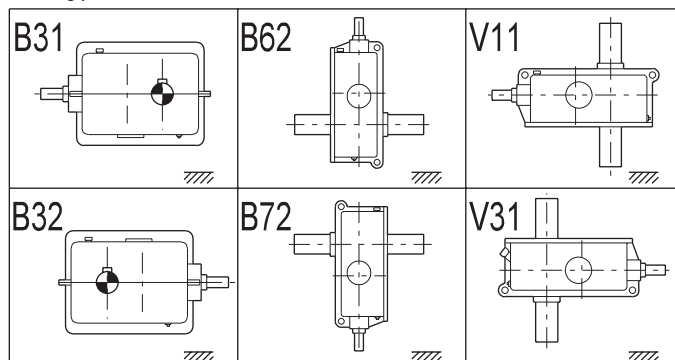

Posición extremos de árboles y Sentidos de giro
Shafts position and direction of rotation

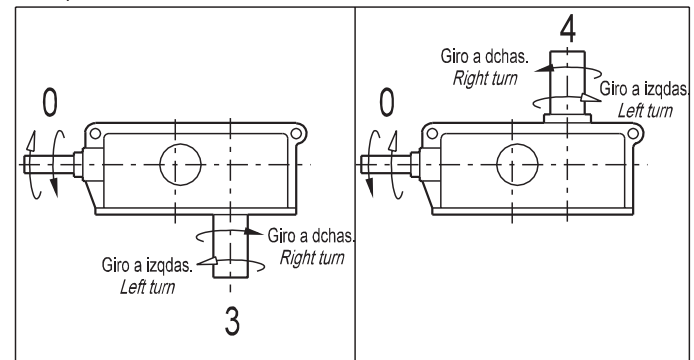

Equipamientos Técnicos Comerciales, S.A. se reserva el derecho de realizar cualquier modificación. / Equipamientos Técnicos Comerciales, S.A. reserves the right to modification.

REDUCTORES TIPO TTH / TTH TYPE GEAR UNITS

TRES TRENES DE ENGRANAJES - EJES PERPENDICULARES
THREE STAGES - PERPENDICULAR SHAFTS

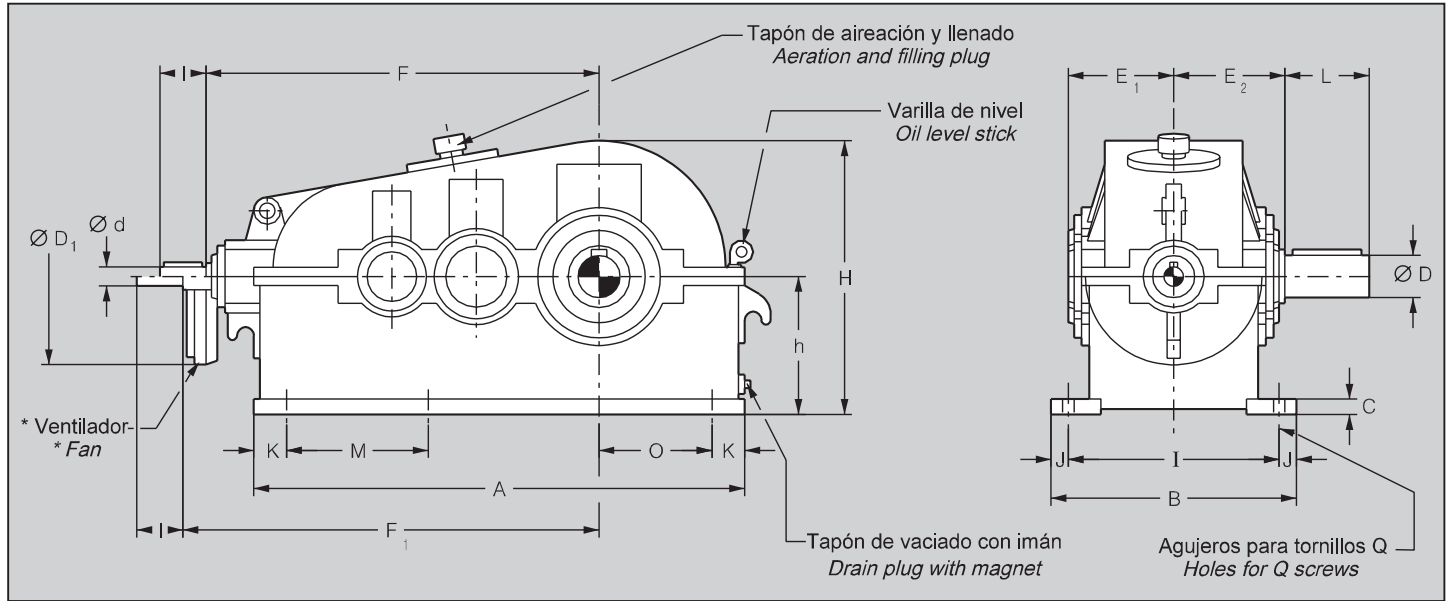

Extremos de árboles con chavetas DIN 6885 h1. Dimensiones: Pág 41.
Puntos de centrado con rosca forma D DIN 332. Dimensiones: Pág 41.
Tolerancia en extremos de árboles: Hasta Ø50 mm. ISO k6., superiores ISO m6.
* Situación orientativa. Si necesita ventilador se estudiará, en cada caso, la situación idónea.
1) Hasta 250 mm., tolerancia -0,5, superiores -1
2) Solamente para posición de trabajo B3.
N = Cantidad de agujeros en la base.

Shafts ends with keys to DIN 6885 h1. Dimensions: page 41.
Centering points with thread to D DIN 332. Dimensions: page 41.
Tolerance of shaft ends: up to Ø50 mm. ISO k6., bigger ones ISO m6.
* Approximated situation. If fan is needed, the suitable situation will be studied in every case.
1) Up to 250 mm., tolerance - 0.5, bigger ones - 1.
2) Only for working position B3.
N= Number of holes of the base.

Tamaño Reductor Gear unit size	A	B	C	$i_N < 45$		$i_N 45 \div 63$		$i_N > 63$		D	$\approx D_1$	$\approx E_1$	E_2	F	F_1	$h_{1)}$	$\approx H$	I	J	K	L	M	N	O	Q	Peso = / Kg. Weight = / Kg.	Capacidad de aceite = / l. Quantity of oil = / l.
				d	l	d	l	d	l																		
112	462	252	14	20	50	16	40	16	40	55	180	107	123	370	417	125	262	220	16	24	110	207	6	122	M12	71	3,5
125	514	280	15	25	60	16	40	16	40	60	230	117	133	418	478	140	292	244	18	26	120	231	6	134	M14	95	5,5
140	580	314	16	25	60	20	50	16	40	65	230	130	148	460	520	160	332	274	20	30	140	260	6	149	M16	137	8
160	646	358	18	30	80	25	60	20	50	75	300	152	170	514	584	180	367	318	20	35	140	288	6	162	M16	192	12
180	720	392	20	35	80	30	80	25	60	85	340	165	183	572	655	200	409	348	22	40	170	320	6	178	M18	285	16
200	807	422	22	40	110	35	80	25	60	95	340	172	190	645	728	225	454	372	25	45	170	239	8	192	M20	364	21
225	898	468	25	45	110	40	110	30	80	110	410	192	210	715	844	250	504	412	28	50	210	266	8	213	M22	480	28
250	1.004	526	28	50	110	45	110	35	80	120	410	216	236	797	926	280	565	466	30	55	210	298	8	237	M24	650	41
280	1.122	558	31	50	110	45	110	35	80	130	500	237	257	885	1.030	315	636	498	30	60	250	334	8	269	M24	830	58
315	1.244	620	34	55	110	50	110	40	110	150	500	268	288	986	1.131	355	703	560	30	70	250	276	10	288	M24	1.180	83
355	1.400	690	36	60	140	50	110	45	110	170	500	297	317	1.110	1.255	400	775	626	32	80	300	310	10	320	M27	1.570	123
400	1.572	726	40	65	140	60	140	50	110	190	500	313	333	1.245	1.390	450	872	662	32	90	350	348	10	357	M27	2.140	165
450	1.760	804	43	80	170	65	140	55	110	210	700	340	372	1.394	1.539	500	967	734	35	100	350	390	10	399	M30	3.000	230
500	1.952	878	45	90	170	70	140	65	140	230	700	379	411	1.542	1.687	560	1.078	808	35	110	410	433	10	443	M30	4.150	325
560	2.200	978	48	100	210	80	170	70	140	260	850	419	451	1.733	1.878	630	1.212	902	38	120	410	392	12	502	M33	5.600	474
630	2.495	1.076	55	110	210	95	170	80	170	300	850	458	490	1.956	2.101	710	1.380	986	45	135	470	445	12	575	M36	7.700	666
710	2.790	1.184	62	120	210	100	210	85	170	330	850	512	544	2.188	2.333	800	1.550	1.094	45	150	470	498	12	640	M39	10.100	952
800	3.135	1.322	70	130	250	110	210	95	170	370	850	569	601	2.458	2.603	900	1.745	1.222	50	170	550	559	12	715	M42	12.600	1.352

Posiciones de trabajo Working positions

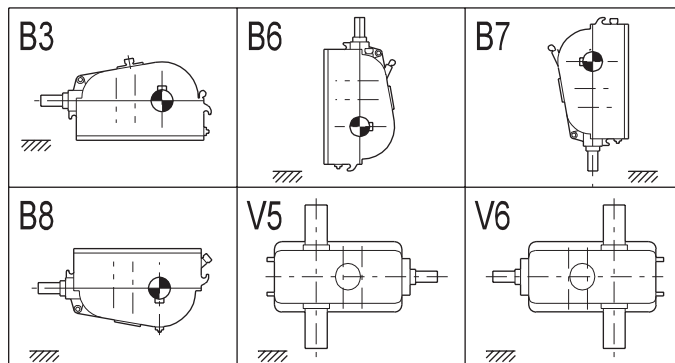

Posición extremos de árboles y Sentidos de giro Shafts position and direction of rotation

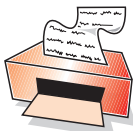
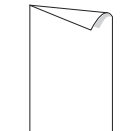
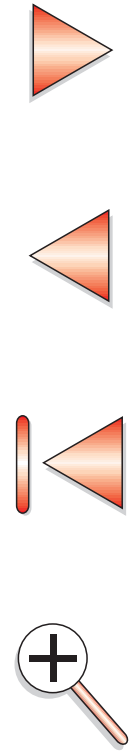
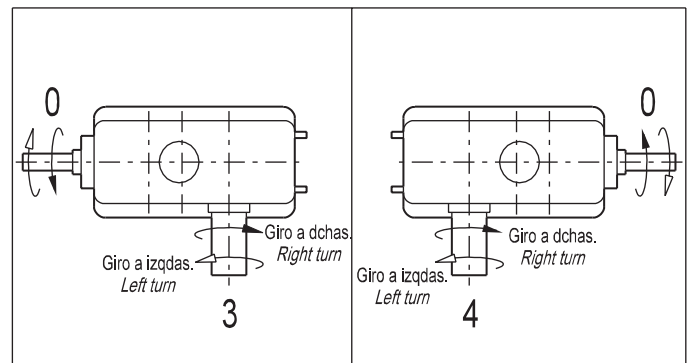

REDUCTORES TIPO TTHA / TTHA TYPE GEAR UNITS

TRES TRENES DE ENGRANAJES - EJES PERPENDICULARES - ARBOL LENTO HUECO
THREE STAGES - PERPENDICULAR SHAFTS - HOLLOW SLOW SHAFT

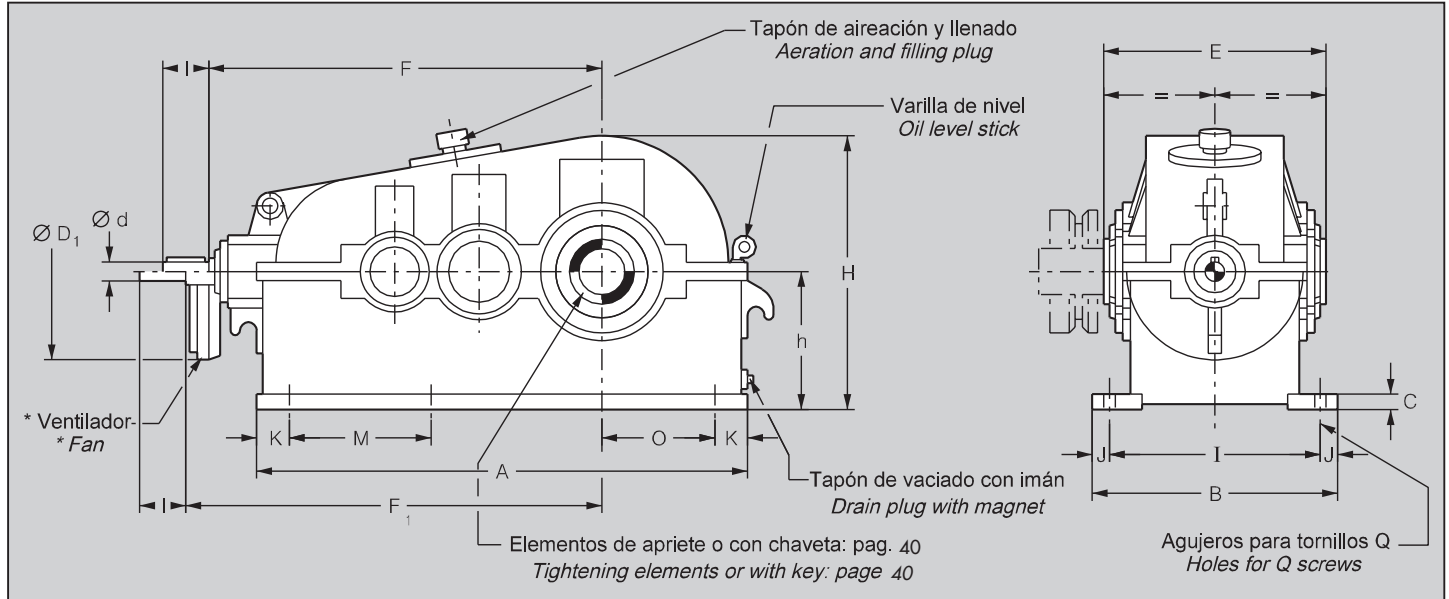

Extremos de árboles con chavetas DIN 6885 h1. Dimensiones: Pág 41.
Puntos de centrado con rosca forma D DIN 332. Dimensiones: Pág 41.
Tolerancia en extremos de árboles: Hasta Ø50 mm. ISO k6., superiores ISO m6.
* Situación orientativa. Si necesita ventilador se estudiará, en cada caso, la situación idónea.
1) Hasta 250 mm., tolerancia -0,5, superiores -1
2) Solamente para posición de trabajo B3.

Shafts ends with keys to DIN 6885 h1. Dimensions: page 41.
Centering points with thread to D DIN 332. Dimensions: page 41.
Tolerance of shaft ends: up to Ø50 mm. ISO k6., bigger ones ISO m6.
* Approximated situation. If fan is needed, the suitable situation will be studied in every case.
1) Up to 250 mm.. tolerance - 0.5, bigger ones - 1.
2) Only for working position B3.
N= Number of holes of the base.

Tamaño Reductor Gear unit size	A	B	C	$i_N < 45$		$i_N 45 + 63$		$i_N > 63$		$\approx D_1$	E	F	F ₁	h ₁	$\approx H$	I	J	K	M	N	O	Q	Peso = / Kg. Weight = / Kg.	Capacidad de aceite = / l. Quantity of oil = / l.
				d	l	d	l	d	l															
112	462	252	14	20	50	16	40	16	40	180	246	370	417	125	262	220	16	24	207	6	122	M12	71	3,5
125	514	280	15	25	60	16	40	16	40	230	266	418	478	140	292	244	18	26	231	6	134	M14	95	5,5
140	580	314	16	25	60	20	50	16	40	230	296	460	520	160	332	274	20	30	260	6	149	M16	137	8
160	646	358	18	30	80	25	60	20	50	300	340	514	584	180	367	318	20	35	288	6	162	M16	192	12
180	720	392	20	35	80	30	80	25	60	340	366	572	655	200	409	348	22	40	320	6	178	M18	285	16
200	807	422	22	40	110	35	80	25	60	340	380	645	728	225	454	372	25	45	239	8	192	M20	364	21
225	898	468	25	45	110	40	110	30	80	410	420	715	844	250	504	412	28	50	266	8	213	M22	480	28
250	1.004	526	28	50	110	45	110	35	80	410	472	797	926	280	565	466	30	55	298	8	237	M24	650	41
280	1.122	558	31	50	110	45	110	35	80	500	514	885	1.030	315	636	498	30	60	334	8	269	M24	830	58
315	1.244	620	34	55	110	50	110	40	110	500	576	986	1.131	355	703	560	30	70	276	10	288	M24	1.180	83
355	1.400	690	36	60	140	50	110	45	110	500	634	1.110	1.255	400	775	626	32	80	310	10	320	M27	1.570	123
400	1.572	726	40	65	140	60	140	50	110	500	666	1.245	1.390	450	872	662	32	90	348	10	357	M27	2.140	165
450	1.760	804	43	80	170	65	140	55	110	700	744	1.394	1.539	500	967	734	35	100	390	10	399	M30	3.000	230
500	1.952	878	45	90	170	70	140	65	140	700	822	1.542	1.687	560	1.078	808	35	110	433	10	443	M30	4.150	325
560	2.200	978	48	100	210	80	170	70	140	850	902	1.733	1.878	630	1.212	902	38	120	392	12	502	M33	5.600	474
630	2.495	1.076	55	110	210	95	170	80	170	850	980	1.956	2.101	710	1.380	986	45	135	445	12	575	M36	7.700	666
710	2.790	1.184	62	120	210	100	210	85	170	850	1.088	2.188	2.333	800	1.550	1.094	45	150	498	12	640	M39	10.100	952
800	3.135	1.322	70	130	250	110	210	95	170	850	1.202	2.458	2.603	900	1.745	1.222	50	170	559	12	715	M42	12.600	1.352

Posiciones de trabajo Working positions

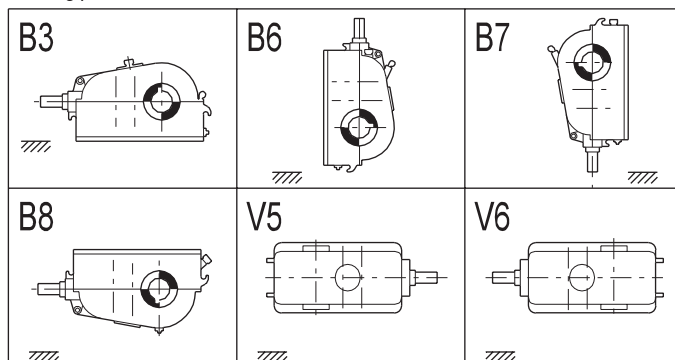

Posición extremos de árboles y Sentidos de giro Shafts position and direction of rotation

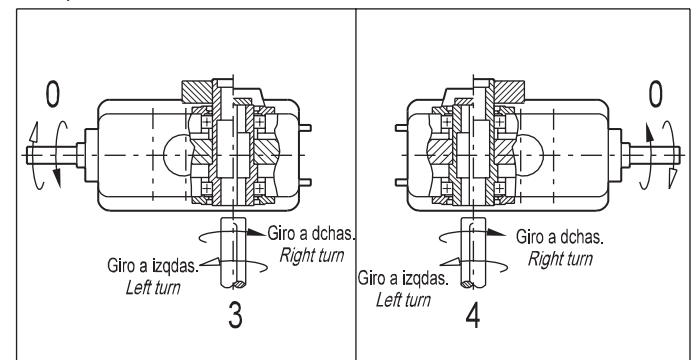

Equipamientos Técnicos Comerciales, S.A. se reserva el derecho de realizar cualquier modificación. / Equipamientos Técnicos Comerciales, S.A. reserves the right to modification.



REDUCTORES TIPO PTHA / PTHA TYPE GEAR UNITS

TRES TRENES DE ENGRANAJES - EJES PERPENDICULARES - ARBOL LENTO HUECO
THREE STAGES - PERPENDICULAR SHAFTS - HOLLOW SLOW SHAFT

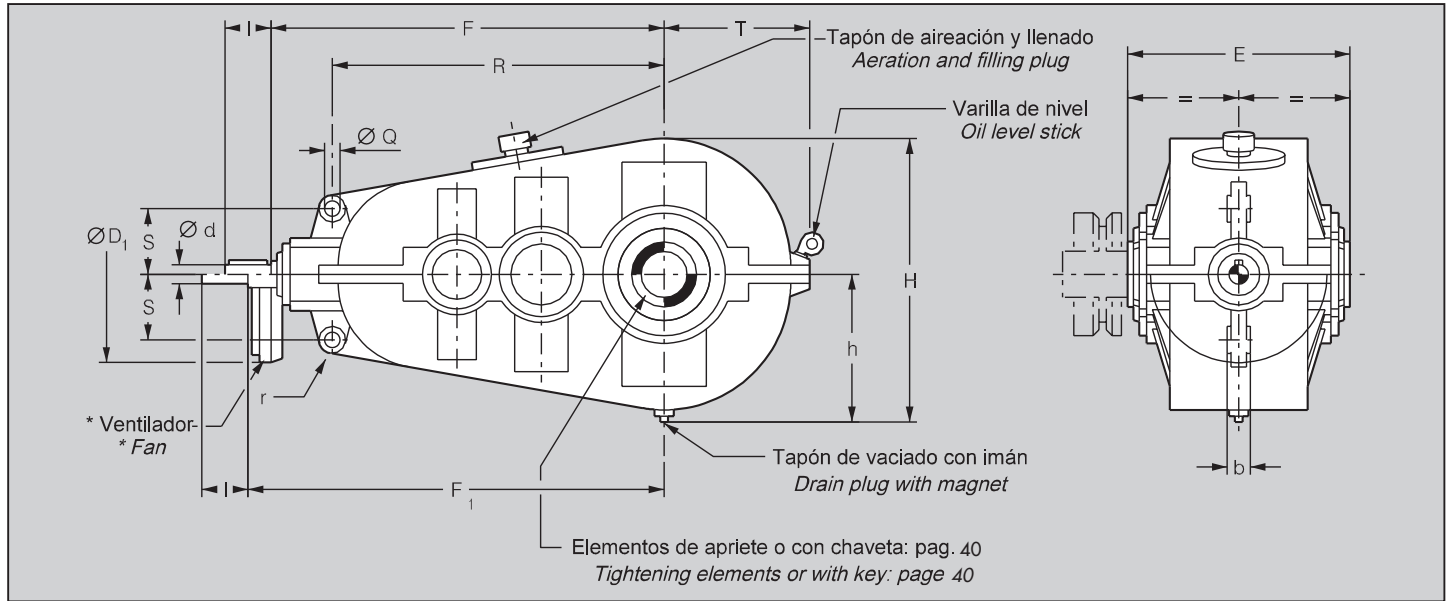

Extremos de árboles con chavetas DIN 6885 h1. Dimensiones: Pág 41.
Puntos de centrado con rosca forma D DIN 332. Dimensiones: Pág 41.
Tolerancia en extremos de árboles: Hasta Ø50 mm. ISO k6., superiores ISO m6.
* Situación orientativa. Si necesita ventilador se estudiará, en cada caso, la situación idónea.
1) Solamente para posición de trabajo B5.

Shafts ends with keys to DIN 6885 h1. Dimensions: page 41.
Centering points with thread to D DIN 332. Dimensions: page 41.
Tolerance of shaft ends: up to Ø50 mm. ISO k6, bigger ones ISO m6.
* Approximated situation. If fan is needed, the suitable situation will be studied in every case.
1) Only for working position B5.

Tamaño Reductor Gear unit size	b	$i_N < 45$		$i_N 45 \div 63$		$i_N > 63$		$\approx D_1$	E	F	F ₁	$\approx h$	$\approx H$	Q	r	R	S	T	Peso = / Kg. Weight = / Kg	Capacidad de aceite = / l. Quantity of oil = / l.
		d	l	d	l	d	l													
112	18	20	50	16	40	16	40	180	246	370	417	143	280	16	16	316	70	153	68	2,5
125	20	25	60	16	40	16	40	230	266	418	478	158	310	18	18	350	76	167	87	4
140	22	25	60	20	50	16	40	230	296	460	520	178	350	18	18	400	85	187	121	5,5
160	25	30	80	25	60	20	50	300	340	514	584	193	376	20	20	446	97	205	170	8
180	28	35	80	30	80	25	60	340	366	572	655	215	424	25	25	495	95	225	250	11,5
200	32	40	110	35	80	25	60	340	380	645	728	235	464	25	25	565	103	247	325	16
225	35	45	110	40	110	30	80	410	420	715	844	260	514	28	28	630	115	275	430	20
250	44	50	110	45	110	35	80	410	472	797	926	293	578	28	28	712	130	305	580	28
280	44	50	110	45	110	35	80	500	514	885	1.030	329	650	30	30	794	145	343	735	38
315	48	55	110	50	110	40	110	500	576	986	1.131	356	704	35	35	882	160	373	1.050	51
355	55	60	140	50	110	45	110	500	634	1.110	1.255	383	758	40	40	975	180	400	1.410	68
400	60	65	140	60	140	50	110	500	666	1.245	1.390	430	852	45	45	1.095	200	447	1.930	91
450	70	80	170	65	140	55	110	700	744	1.394	1.539	477	944	50	50	1.230	225	499	2.700	120
500	80	90	170	70	140	65	140	700	822	1.542	1.687	528	1.046	55	55	1.370	250	553	3.800	165
560	90	100	210	80	170	70	140	850	902	1.733	1.878	592	1.174	60	60	1.550	285	622	5.100	242
630	100	110	210	95	170	80	170	850	980	1.956	2.101	682	1.352	75	75	1.750	320	710	7.100	362
710	110	120	210	100	210	85	170	850	1.088	2.188	2.333	762	1.512	85	85	1.960	360	790	9.100	504
800	120	130	250	110	210	95	170	850	1.202	2.458	2.603	857	1.702	95	95	2.200	405	885	11.100	740

Posiciones de trabajo Working positions

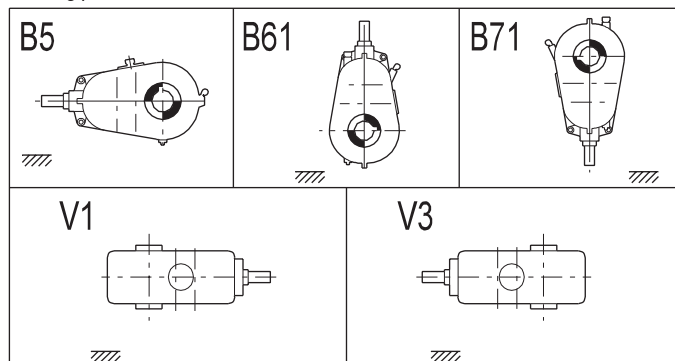

Posición extremos de árboles y Sentidos de giro Shafts position and direction of rotation

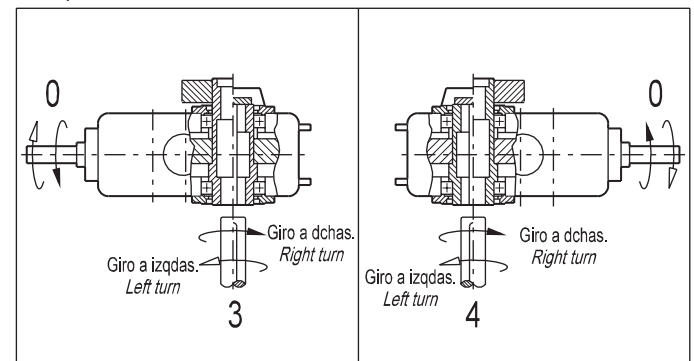

Equipamientos Técnicos Comerciales, S.A. se reserva el derecho de realizar cualquier modificación. / Equipamientos Técnicos Comerciales, S.A. reserves the right to modification.

REDUCTORES TIPO TTHV / TTHV TYPE GEAR UNITS

TRES TRENES DE ENGRANAJES - EJES PERPENDICULARES
THREE STAGES - PERPENDICULAR SHAFTS

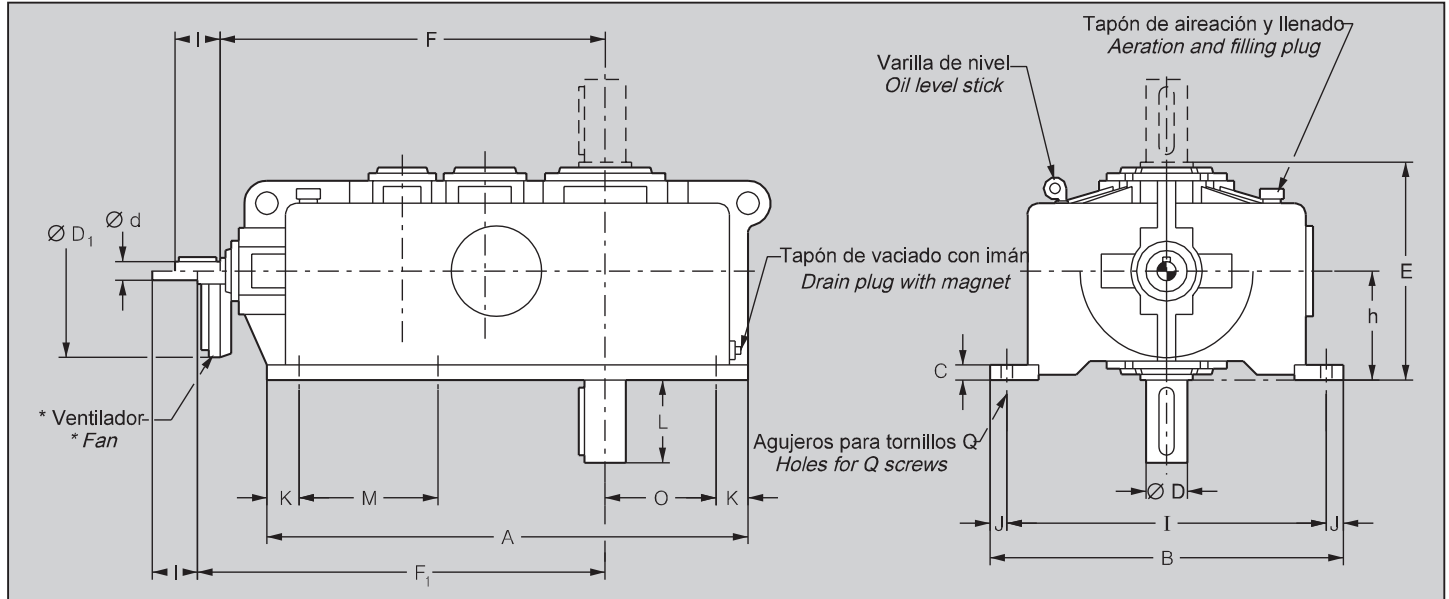

Extremos de árboles con chavetas DIN 6885 h1. Dimensiones: Pág 41.
Puntos de centrado con rosca forma D DIN 332. Dimensiones: Pág 41.
Tolerancia en extremos de árboles: Hasta Ø50 mm. ISO k6., superiores ISO m6.
* Situación orientativa. Si necesita ventilador se estudiará, en cada caso, la situación idónea.
1) Hasta 250 mm., tolerancia -0,5, superiores -1
2) Solamente para posición de trabajo V11 y V31.
N = Cantidad de agujeros en la base.

Shafts ends with keys to DIN 6885 h1. Dimensions: page 41.
Centering points with thread to D DIN 332. Dimensions: page 41.
Tolerance of shaft ends: up to Ø50 mm. ISO k6., bigger ones ISO m6.
* Approximated situation. If fan is needed, the suitable situation will be studied in every case.
1) Up to 250 mm.. tolerance - 0.5, bigger ones - 1.
2) Only for working position V11 y V31.
N= Number of holes of the base.

Tamaño Reductor Gear unit size	A	B	C	$i_N < 45$		$i_N 45 + 63$		$i_N > 63$		D	$\approx D_1$	E	F	F ₁	h ₁	I	J	K	L	M	N	O	Q	Peso = / Kg. Weight = / Kg.	Capacidad de aceite = / l. Quantity of oil = / l.
				d	l	d	l	d	l																
112	462	336	14	20	50	16	40	16	40	55	180	246	370	417	123	304	16	24	110	207	6	122	M12	82	5,5
125	514	376	15	25	60	16	40	16	40	60	230	266	418	478	133	340	18	26	120	231	6	134	M14	104	8
140	580	420	16	25	60	20	50	16	40	65	230	296	460	520	148	380	20	30	140	260	6	149	M16	147	10
160	646	462	18	30	80	25	60	20	50	75	300	340	514	584	170	422	20	35	140	288	6	162	M16	205	15
180	720	510	20	35	80	30	80	25	60	85	340	366	572	655	183	466	22	40	170	320	6	178	M18	308	20
200	807	574	22	40	110	35	80	25	60	95	340	380	645	728	190	524	25	45	170	239	8	192	M20	395	27
225	898	630	25	45	110	40	110	30	80	110	410	420	715	844	210	574	28	50	210	266	8	213	M22	520	39
250	1.004	700	28	50	110	45	110	35	80	120	410	472	797	926	236	640	30	55	210	298	8	237	M24	690	55
280	1.122	758	31	50	110	45	110	35	80	130	500	514	885	1.030	257	698	30	60	250	334	8	269	M24	890	79
315	1.244	828	34	55	110	50	110	40	110	150	500	576	986	1.131	288	768	30	70	250	276	10	288	M24	1.270	106
355	1.400	914	36	60	140	50	110	45	110	170	500	634	1.110	1.255	317	850	32	80	300	310	10	320	M27	1.680	155
400	1.572	1.036	40	65	140	60	140	50	110	190	500	666	1.245	1.390	333	972	32	90	350	348	10	357	M27	2.300	210
450	1.760	1.136	43	80	170	65	140	55	110	210	700	744	1.394	1.539	372	1.066	35	100	350	390	10	399	M30	3.230	315
500	1.952	1.240	45	90	170	70	140	65	140	230	700	822	1.542	1.687	411	1.170	35	110	410	433	10	443	M30	4.450	400
560	2.200	1.404	48	100	210	80	170	70	140	260	850	902	1.733	1.878	451	1.328	38	120	410	392	12	502	M33	5.900	600
630	2.495	1.570	55	110	210	95	170	80	170	300	850	980	1.956	2.101	490	1.480	45	135	470	445	12	575	M36	8.100	860
710	2.790	1.716	62	120	210	100	210	85	170	330	850	1.088	2.188	2.333	544	1.626	45	150	470	498	12	640	M39	10.600	1.210
800	3.135	1.896	70	130	250	110	210	95	170	370	850	1.202	2.458	2.603	601	1.796	50	170	550	559	12	715	M42	13.200	1.700

Posiciones de trabajo
Working positions

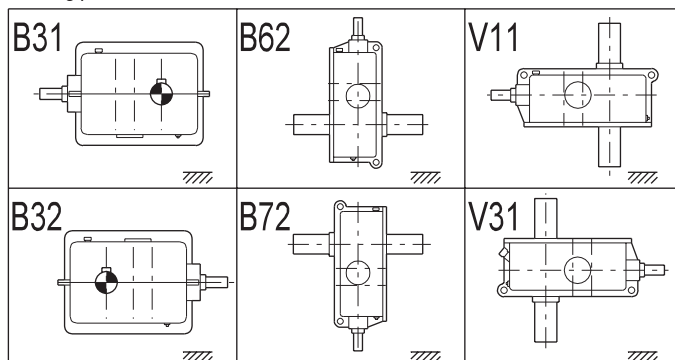

Posición extremos de árboles y Sentidos de giro
Shafts position and direction of rotation

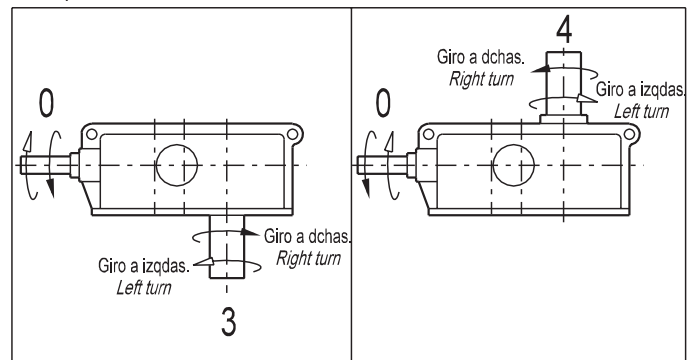

Equipamientos Técnicos Comerciales, S.A. se reserva el derecho de realizar cualquier modificación. / Equipamientos Técnicos Comerciales, S.A. reserves the right to modification.

REDUCTORES TIPO TCH-TCHA-PCHA-TCHV / TCH-TCHA-PCHA-TCHV TYPE GEAR UNITS



CUATRO TRENES DE ENGRANAJES - EJES PERPENDICULARES

FOUR STAGES - PERPENDICULAR SHAFTS

Relación de transmisión. i_N Transmission ratio	Velocidades r. p. m. / Speeds		TAMAÑO REDUCTOR / GEAR UNIT SIZE														
	n_1	n_2	160	180	200	225	250	280	315	355	400	450	500	560	630	710	800
			Potencia P en Kw. / Power P in Kw.														
112	1.500	13,4	6	9	15	20	29	40	59	85	112	165	250	350	470	670	930
	1.000	8,9	4	6	10	13	19	26	39	56	75	110	170	235	315	445	620
	750	6,7	3	4,5	7,5	9,7	14	19,5	29	42	56	82	128	176	236	335	465
125	1.500	12	6	9	12	18,5	26	35	50	78	102	145	225	310	425	590	850
	1.000	8	4	6	8	12	17	23	33	52	68	96	150	206	285	395	570
	750	6	3	4,5	6	9	12,5	17	25	39	51	72	112	155	215	300	430
140	1.500	10,7	5,6	8,3	11	16,5	22,5	32	45	70	90	130	200	280	375	530	750
	1.000	7,1	3,7	5,5	7,3	11	15	21	30	46	60	86	135	190	250	355	500
	750	5,4	2,7	4	5,5	8,2	11	15,5	22,5	34	45	64	102	142	190	266	375
160	1.500	9,4	5,4	7,5	9,5	14	20	28	40	60	80	115	178	250	335	480	680
	1.000	6,3	3,6	5	6,3	9	13,3	18,5	26	40	53	76	120	170	225	320	455
	750	4,7	2,7	3,7	4,7	6,7	10	14	19,5	30	40	57	90	130	170	240	342
180	1.500	8,3	5,4	6,5	8,2	13	19	25	36	55	70	102	155	220	300	430	620
	1.000	5,6	3,6	4,3	5,5	8,5	12,5	16,5	24	37	47	68	105	146	200	290	415
	750	4,2	2,7	3,2	4	6,3	9	12	18	28	35	51	78	110	150	218	312
200	1.500	7,5	5	5,5	7,5	12	15,5	22	32	50	63	92	142	200	270	385	545
	1.000	5	3,3	3,5	5	8	10	14,5	21	33	42	62	95	135	180	260	365
	750	3,8	2,4	2,5	3,75	6	7,5	11	15,5	25	31	46	72	102	135	195	275
225	1.500	6,6	4,1	4,6	6,5	10	14	20	29	45	57	80	125	180	240	350	500
	1.000	4,4	2,7	3	4,2	6,5	9,3	13	19	30	38	53	83	120	160	233	335
	750	3,3	2	2,2	3	4,8	7	9,5	14	22	28	40	62	90	120	175	252
250	1.500	6	3,3	4,3	6	9	12,5	17	26	40	50	71	112	160	215	310	435
	1.000	4	2,2	2,8	4	6	8,3	11	17	27	33	47	75	106	145	206	290
	750	3	1,6	1,8	3	4,5	6	8	12,5	20	25	35	56	80	110	155	217
280	1.500	5,4	3,3	3,9	5,3	8	11	15,5	22	35	45	65	100	140	190	270	385
	1.000	3,6	2,2	2,6	3,5	5,3	7,3	10	14,5	23	30	43	67	95	126	180	260
	750	2,7	1,6	1,7	2,6	4	5,5	7,5	11	17	22	32	50	71	95	135	195
315	1.500	4,8	3,3	3,5	4,5	7,5	9,5	13	20	31	42	57	90	125	170	240	345
	1.000	3,2	2,2	2,3	3	5	6,3	8,5	13	20	28	38	60	85	115	160	230
	750	2,4	1,6	1,6	2,2	3,75	4,7	6	9,5	15	21	28	45	64	86	120	172
355	1.500	4,2	2,8	2,8	4	6,5	8,5	12	18	28	37	50	80	112	150	220	310
	1.000	2,8	1,8	1,9	2,6	4,3	5,5	8	12	19	25	33	53	75	100	146	206
	750	2,1	1,3	1,4	1,9	3,2	4	6	9	14	19	25	40	56	75	110	155
400	1.500	3,8	2,3	2,5	3,5	6	8	11	16	25	32	45	70	100	132	190	265
	1.000	2,5	1,5	1,6	2,3	4	5	7,3	10,5	16	21	30	46	66	88	126	180
	750	1,9	1,1	1,2	1,7	3	3,7	5,5	8	12	16	22	34	50	66	95	135
450	1.500	3,3	2,3	2,3	3,2	5	7	10	13,5	21	28	40	62	90	122	172	235
	1.000	2,2	1,5	1,6	2,1	3,3	4,5	6,5	9	14	18	26	41	60	81	115	156
	750	1,7	1,1	1,2	1,5	2,4	3,3	4,8	6,5	10,5	13,5	19	31	45	61	86	117
500	1.500	3	2,3	2	2,7	4,2	6,2	9	12	18	25	36	58	82	110	150	215
	1.000	2	1,5	1,3	1,8	2,8	4	6	8	12	16	24	40	55	73	100	145
	750	1,5	1,1	0,9	1,3	2	3	4,5	6	9	12	18	30	41	55	75	110
560	1.500	2,7	1,9	1,8	2,3	3,7	5	7,5	11	15,5	21	32	48	65	92	130	190
	1.000	1,8	1,2	1,2	1,5	2,4	3,3	5	7,3	10	14	21	32	43	62	86	126
	750	1,3	0,9	0,9	1,1	1,8	2,5	3,7	5,5	7,5	10,5	16	24	32	46	64	94
630	1.500	2,4	1,7	1,6	2	3,2	4,5	6,5	9	13	20	28	45	60	84	115	165
	1.000	1,6	1,1	1	1,3	2,1	3	4,3	6	8,5	13	18	30	40	56	76	110
	750	1,2	0,8	0,75	0,9	1,5	2,2	3	4,5	6	9,5	13,5	22,5	30	42	57	82

Variación máxima de la relación de transmisión $\pm 3\%$ (se pueden solicitar variaciones más restringidas).
A petición se consiguen relaciones de transmisión intermedias.

Maximum variation for transmission ratio $\pm 3\%$. (More limited variations can be requested).
By request intermediate transmission ratios are obtained.

i_N	r. p. m. n_1	TAMAÑO REDUCTOR / GEAR UNIT SIZE														
		160	180	200	225	250	280	315	355	400	450	500	560	630	710	800
		Potencia límite térmica P_G en Kw. / Maximum thermal capacity P_G in Kw.														
P_{G1} para reductores sin refrigeración / P_{G1} for gear units without cooling.																
112 a 630	1.500	17	22	28	37	47	60	75	92	120	155	195	245	305	380	480
	1.000	15,5	18	24	34	42	51	65	85	110	140	180	230	290	365	465
	750	14	17	22	30	38	47	60	75	105	130	165	210	280	345	450

REDUCTORES TIPO TCH / TCH TYPE GEAR UNITS

CUATRO TRENES DE ENGRANAJES - EJES PERPENDICULARES

FOUR STAGES - PERPENDICULAR SHAFTS

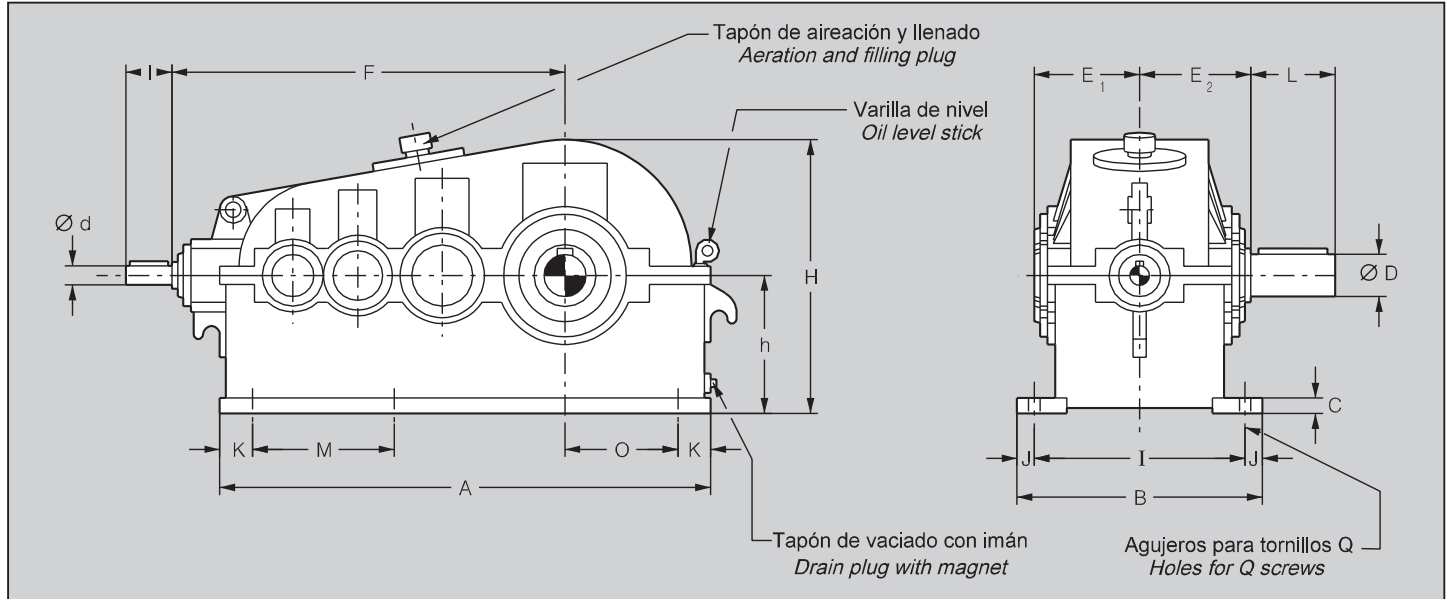

Extremos de árboles con chavetas DIN 6885 h1. Dimensiones: Pág 41.
 Puntos de centrado con rosca forma D DIN 332. Dimensiones: Pág 41.
 Tolerancia en extremos de árboles: Hasta Ø50 mm. ISO k6., superiores ISO m6.
 1) Hasta 250 mm., tolerancia -0,5, superiores -1
 2) Solamente para posición de trabajo B3.
 N = Cantidad de agujeros en la base.

Shafts ends with keys to DIN 6885 h1. Dimensions: page 41.
 Centering points with thread to D DIN 332. Dimensions: page 41.
 Tolerance of shaft ends: up to Ø50 mm. ISO k6, bigger ones ISO m6.
 1) Up to 250 mm.. tolerance - 0.5, bigger ones -1.
 2) Only for working position B3.
 N= Number of holes of the base.

Tamaño Reductor Gear unit size	A	B	C	$i_N < 200$		$i_N 200 \div 355$		$i_N > 355$		D	$\approx E_1$	E_2	F	h ₁₎	$\approx H$	I	J	K	L	M	N	O	Q	Peso = / Kg. Weight = / Kg.	Capacidad de aceite = / l. Quantity of oil = / l. 2)
				d	l	d	l	d	l																
160	646	358	18	16	40	16	40	16	40	75	152	170	530	180	367	318	20	35	140	288	6	162	M16	190	13
180	720	392	20	16	40	16	40	16	40	85	165	183	598	200	409	348	22	40	170	320	6	178	M18	282	17
200	807	422	22	20	50	16	40	16	40	95	172	190	660	225	454	372	25	45	170	239	8	192	M20	358	22
225	898	468	25	25	60	20	50	16	40	110	192	210	739	250	504	412	28	50	210	266	8	213	M22	472	30
250	1.004	526	28	30	80	25	60	20	50	120	216	236	822	280	565	466	30	55	210	298	8	237	M24	630	44
280	1.122	558	31	35	80	25	60	20	50	130	237	257	925	315	636	498	30	60	250	334	8	269	M24	800	62
315	1.244	620	34	40	110	30	80	25	60	150	268	288	1.030	355	703	560	30	70	250	276	10	288	M24	1.160	89
355	1.400	690	36	45	110	35	80	30	80	170	297	317	1.152	400	775	626	32	80	300	310	10	320	M27	1.500	132
400	1.572	726	40	45	110	35	80	30	80	190	313	333	1.285	450	872	662	32	90	350	348	10	357	M27	2.050	177
450	1.760	804	43	50	110	40	110	35	80	210	340	372	1.436	500	967	734	35	100	350	390	10	399	M30	2.900	247
500	1.952	878	45	50	110	45	110	40	110	230	379	411	1.610	560	1.078	808	35	110	410	433	10	443	M30	4.000	350
560	2.200	978	48	60	140	50	110	40	110	260	419	451	1.805	630	1.212	902	38	120	410	392	12	502	M33	5.400	510
630	2.495	1.076	55	65	140	55	110	45	110	300	458	490	2.024	710	1.380	986	45	135	470	445	12	575	M36	7.500	715
710	2.790	1.184	62	70	140	65	140	50	110	330	512	544	2.252	800	1.550	1.094	45	150	470	498	12	640	M39	9.850	1.020
800	3.135	1.322	70	80	170	70	140	55	110	370	569	601	2.533	900	1.745	1.222	50	170	550	559	12	715	M42	12.400	1.450

Posiciones de trabajo Working positions

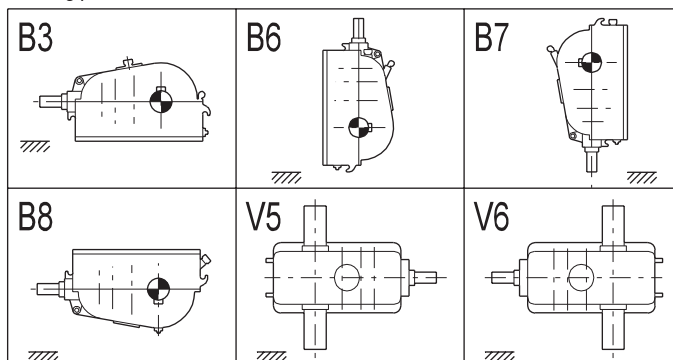

Posición extremos de árboles y Sentidos de giro Shafts position and direction of rotation

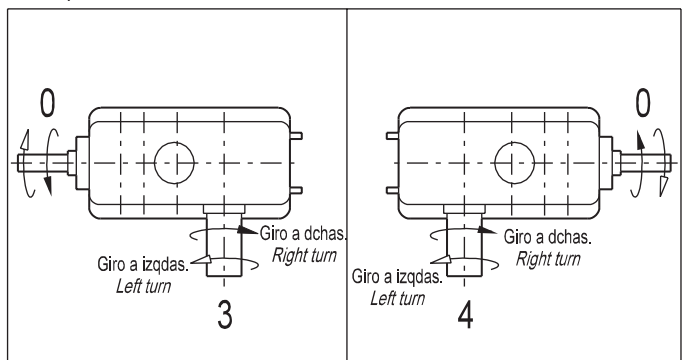

Equipamientos Técnicos Comerciales, S.A. se reserva el derecho de realizar cualquier modificación. / Equipamientos Técnicos Comerciales, S.A. reserves the right to modification.



REDUCTORES TIPO TCHA / TCHA TYPE GEAR UNITS

CUATRO TRENES DE ENGRANAJES - EJES PERPENDICULARES - ARBOL LENTO HUECO
 FOUR STAGES - PERPENDICULAR SHAFTS - HOLLOW SLOW SHAFT

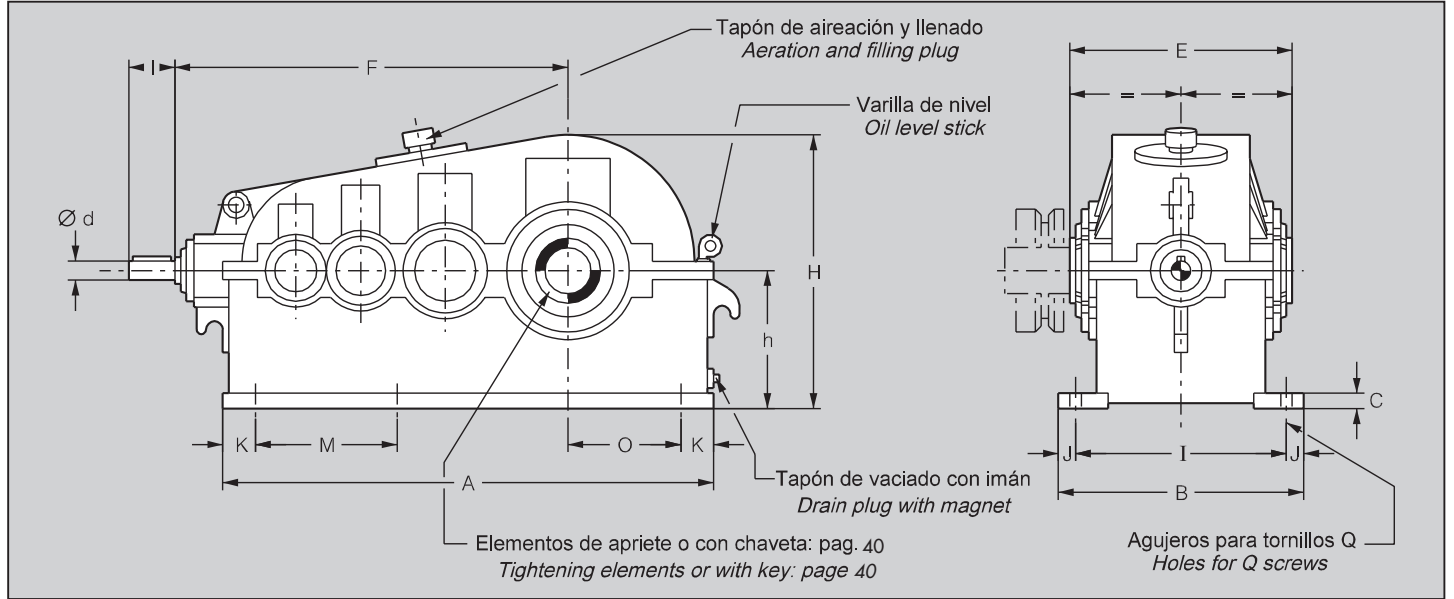

Extremos de árboles con chavetas DIN 6885 h1. Dimensiones: Pág 41.
 Puntos de centrado con rosca forma D DIN 332. Dimensiones: Pág 41.
 Tolerancia en extremos de árboles: Hasta Ø50 mm. ISO k6., superiores ISO m6.
 1) Hasta 250 mm., tolerancia -0,5, superiores -1
 2) Solamente para posición de trabajo B3.
 N = Cantidad de agujeros en la base.

Shafts ends with keys to DIN 6885 h1. Dimensions: page 41.
 Centering points with thread to D DIN 332. Dimensions: page 41.
 Tolerance of shaft ends: up to Ø50 mm. ISO k6, bigger ones ISO m6.
 1) Up to 250 mm., tolerance - 0.5, bigger ones -1.
 2) Only for working position B3.
 N= Number of holes of the base.

Tamaño Reductor Gear unit size	A	B	C	$i_N < 200$		$i_N 200 + 355$		$i_N > 355$		E	F	h ₁₎	H	I	J	K	M	N	O	Q	Peso = / Kg Weight = / Kg	Capacidad de aceite = / l. Quantity of oil = / l. 2)
				d	l	d	l	d	l													
160	646	358	18	16	40	16	40	16	40	340	530	180	367	318	20	35	288	6	162	M16	190	13
180	720	392	20	16	40	16	40	16	40	366	598	200	409	348	22	40	320	6	178	M18	282	17
200	807	422	22	20	50	16	40	16	40	380	660	225	454	372	25	45	239	8	192	M20	358	22
225	898	468	25	25	60	20	50	16	40	420	739	250	504	412	28	50	266	8	213	M22	472	30
250	1.004	526	28	30	80	25	60	20	50	472	822	280	565	466	30	55	298	8	237	M24	630	44
280	1.122	558	31	35	80	25	60	20	50	514	925	315	636	498	30	60	334	8	269	M24	800	62
315	1.244	620	34	40	110	30	80	25	60	576	1.030	355	703	560	30	70	276	10	288	M24	1.160	89
355	1.400	690	36	45	110	35	80	30	80	634	1.152	400	775	626	32	80	310	10	320	M27	1.500	132
400	1.572	726	40	45	110	35	80	30	80	666	1.285	450	872	662	32	90	348	10	357	M27	2.050	177
450	1.760	804	43	50	110	40	110	35	80	744	1.436	500	967	734	35	100	390	10	399	M30	2.900	247
500	1.952	878	45	50	110	45	110	40	110	822	1.610	560	1.078	808	35	110	433	10	443	M30	4.000	350
560	2.200	978	48	60	140	50	110	40	110	902	1.805	630	1.212	902	38	120	392	12	502	M33	5.400	510
630	2.495	1.076	55	65	140	55	110	45	110	980	2.024	710	1.380	986	45	135	445	12	575	M36	7.500	715
710	2.790	1.184	62	70	140	65	140	50	110	1.088	2.252	800	1.550	1.094	45	150	498	12	640	M39	9.850	1.020
800	3.135	1.322	70	80	170	70	140	55	110	1.202	2.533	900	1.745	1.222	50	170	559	12	715	M42	12.400	1.450

Posiciones de trabajo
Working positions

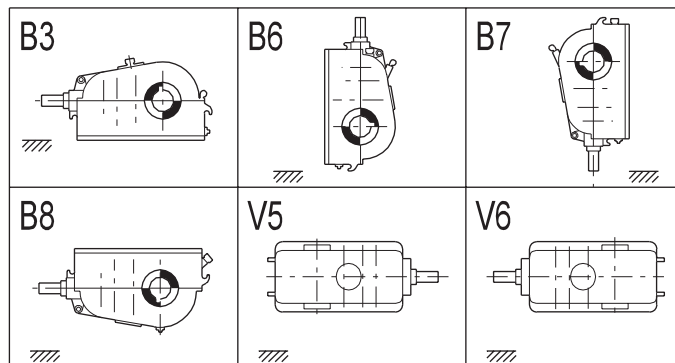

Posición extremos de árboles y Sentidos de giro
Shafts position and direction of rotation

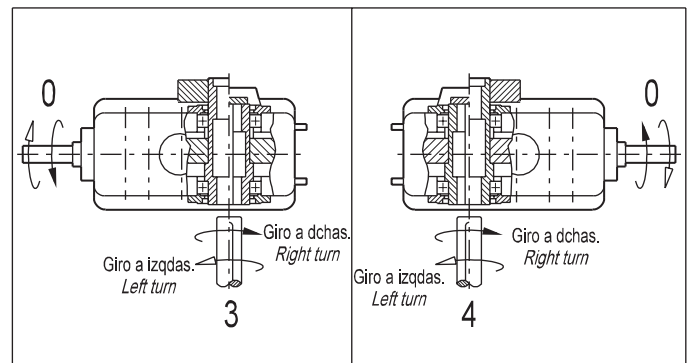

Equipamientos Técnicos Comerciales, S.A. se reserva el derecho de realizar cualquier modificación. / Equipamientos Técnicos Comerciales, S.A. reserves the right to modification.

REDUCTORES TIPO PCHA / PCHA TYPE GEAR UNITS



CUATRO TRENES DE ENGRANAJES - EJES PERPENDICULARES - ARBOL LENTO HUECO
 FOUR STAGES - PERPENDICULAR SHAFTS - HOLLOW SLOW SHAFT

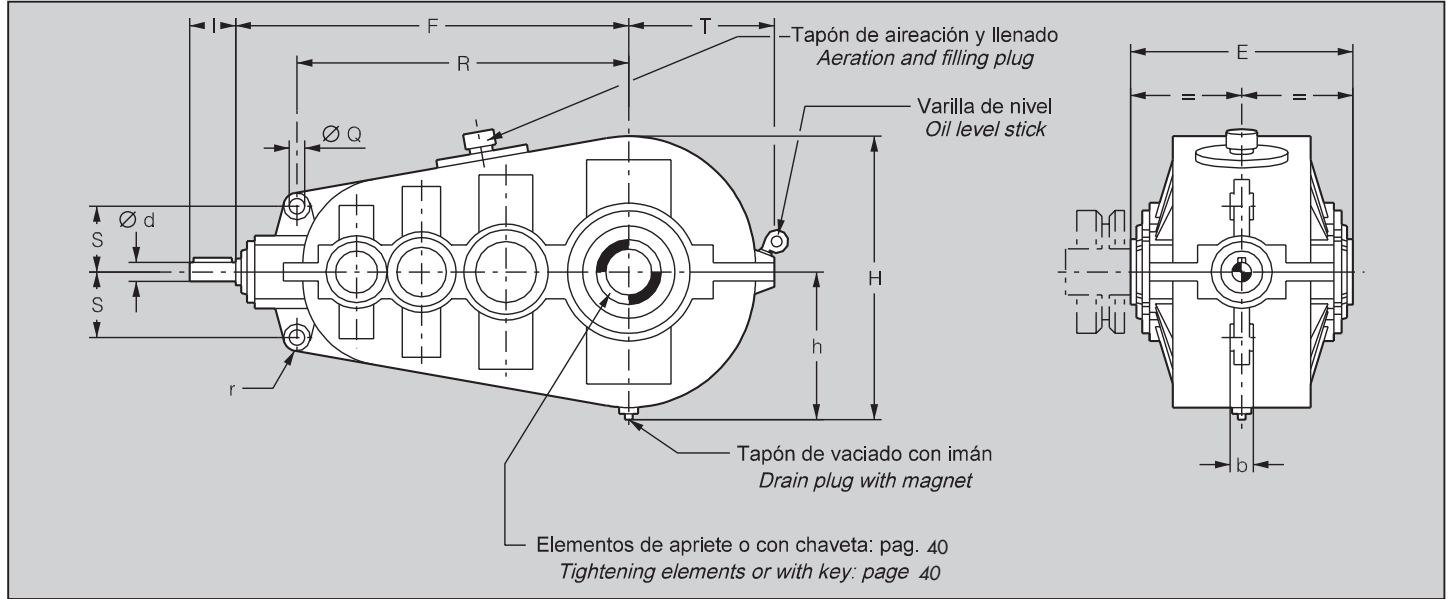

Extremos de árboles con chavetas DIN 6885 h1. Dimensiones: Pág 41.
 Puntos de centrado con rosca forma D DIN 332. Dimensiones: Pág 41.
 Tolerancia en extremos de árboles: Hasta Ø50 mm. ISO k6., superiores ISO m6.
 1) Solamente para posición de trabajo B5.

Shafts ends with keys to DIN 6885 h1. Dimensions: page 41.
 Centering points with thread to D DIN 332. Dimensions: page 41.
 Tolerance of shaft ends: up to Ø50 mm. ISO k6, bigger ones ISO m6.
 1) Only for working position B5.

Tamaño Reductor Gear unit size	b	$i_N < 200$		$i_N 200 + 355$		$i_N > 355$		E	F	h	H	Q	r	R	S	T	Peso = / Kg Weight = / Kg	Capacidad de aceite = / l. Quantity of oil = / l.
		d	l	d	l	d	l											
160	25	16	40	16	40	16	40	340	530	193	376	20	20	446	97	205	165	8
180	28	16	40	16	40	16	40	366	598	215	424	25	25	495	95	225	250	11,5
200	32	20	50	16	40	16	40	380	660	235	464	25	25	565	103	247	315	16
225	35	25	60	20	50	16	40	420	739	260	514	28	28	630	115	275	410	20
250	44	30	80	25	60	20	50	472	822	293	578	28	28	712	130	305	555	28
280	44	35	80	25	60	20	50	514	925	329	650	30	30	794	145	343	700	38
315	48	40	110	30	80	25	60	576	1.030	356	704	35	35	882	160	373	1.000	51
355	55	45	110	35	80	30	80	634	1.152	383	758	40	40	975	180	400	1.340	68
400	60	45	110	35	80	30	80	666	1.285	430	852	45	45	1.095	200	447	1.800	91
450	70	50	110	40	110	35	80	744	1.436	477	944	50	50	1.230	225	499	2.600	120
500	80	50	110	45	110	40	110	822	1.610	528	1.046	55	55	1.370	250	553	3.650	165
560	90	60	140	50	110	40	110	902	1.805	592	1.174	60	60	1.550	285	622	4.900	242
630	100	65	140	55	110	45	110	980	2.024	682	1.352	75	75	1.750	320	710	6.900	362
710	110	70	140	65	140	50	110	1.088	2.252	762	1.512	85	85	1.960	360	790	8.900	504
800	120	80	170	70	140	55	110	1.202	2.533	857	1.702	95	95	2.200	405	885	11.000	740

Posiciones de trabajo Working positions

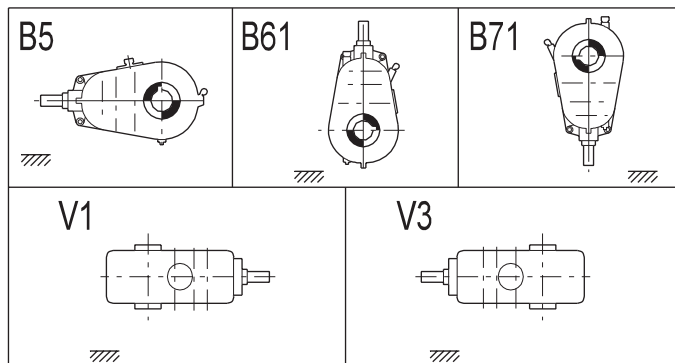

Posición extremos de árboles y Sentidos de giro Shafts position and direction of rotation

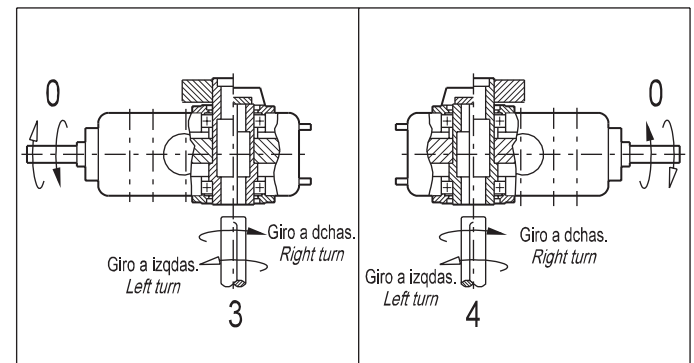

Equipamientos Técnicos Comerciales, S.A. se reserva el derecho de realizar cualquier modificación. / Equipamientos Técnicos Comerciales, S.A. reserves the right to modification.

REDUCTORES TIPO TCHV / TCHV TYPE GEAR UNITS

CUATRO TRENES DE ENGRANAJES - EJES PERPENDICULARES

FOUR STAGES - PERPENDICULAR SHAFTS

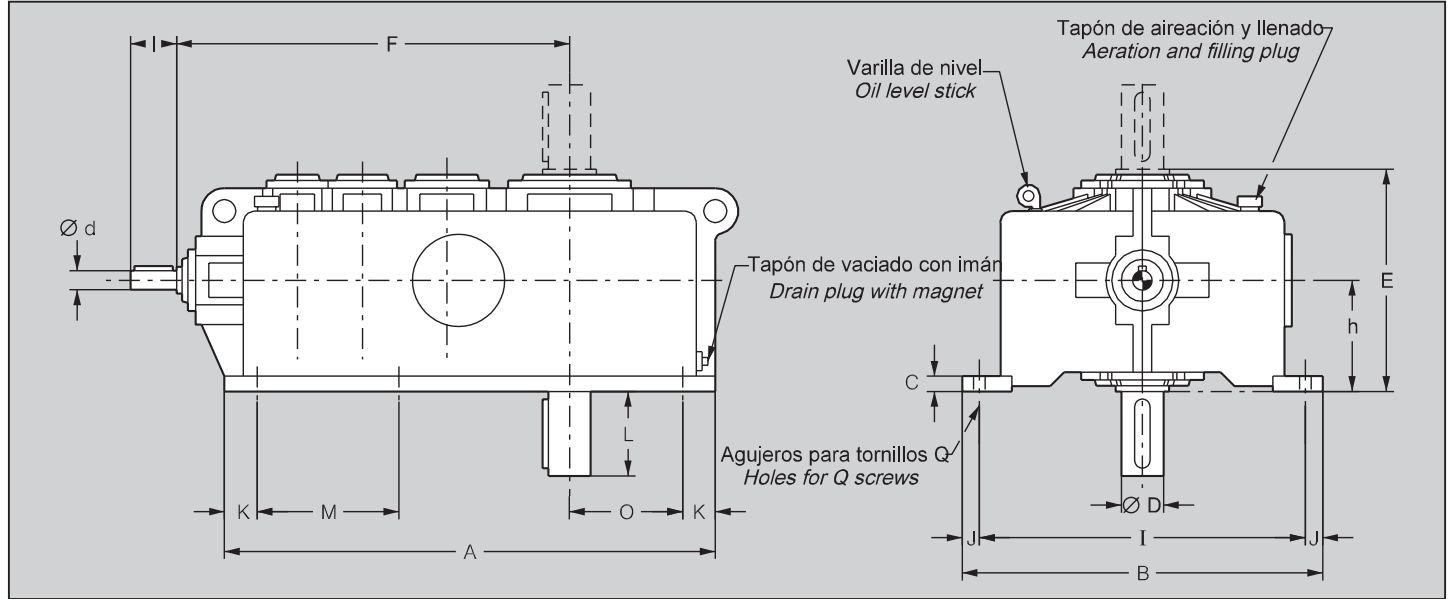

Extremos de árboles con chavetas DIN 6885 h1. Dimensiones: Pág 41.
 Puntos de centrado con rosca forma D DIN 332. Dimensiones: Pág 41.
 Tolerancia en extremos de árboles: Hasta Ø50 mm. ISO k6., superiores ISO m6.
 1) Hasta 250 mm., tolerancia -0,5, superiores -1
 2) Solamente para posición de trabajo V11 y V31.
 N = Cantidad de agujeros en la base.

Shafts ends with keys to DIN 6885 h1. Dimensions: page 41.
 Centering points with thread to D DIN 332. Dimensions: page 41.
 Tolerance of shaft ends: up to Ø50 mm. ISO k6., bigger ones ISO m6.
 1) Up to 250 mm.. tolerance - 0.5, bigger ones -1.
 2) Only for working position V11 y V31.
 N= Number of holes of the base.

Tamaño Reductor Gear unit size	A	B	C	$i_N < 200$		$i_N 200 + 355$		$i_N > 355$		D	E	F	h ₁₎	I	J	K	L	M	N	O	Q	Peso = / Kg Weight = / kg	Capacidad de aceite = / l. Quantity of oil = / l. 2)
				d	l	d	l	d	l														
160	646	462	18	16	40	16	40	16	40	75	340	530	170	422	20	35	140	288	6	162	M16	205	15
180	720	510	20	16	40	16	40	16	40	85	366	598	183	466	22	40	170	320	6	178	M18	308	20
200	807	574	22	20	50	16	40	16	40	95	380	660	190	524	25	45	170	239	8	192	M20	395	27
225	898	630	25	25	60	20	50	16	40	110	420	739	210	574	28	50	210	266	8	213	M22	520	39
250	1.004	700	28	30	80	25	60	20	50	120	472	822	236	640	30	55	210	298	8	237	M24	690	55
280	1.122	758	31	35	80	25	60	20	50	130	514	925	257	698	30	60	250	334	8	269	M24	890	79
315	1.244	828	34	40	110	30	80	25	60	150	576	1.030	288	768	30	70	250	276	10	288	M24	1.270	106
355	1.400	914	36	45	110	35	80	30	80	170	634	1.152	317	850	32	80	300	310	10	320	M27	1.620	155
400	1.572	1.036	40	45	110	35	80	30	80	190	666	1.285	333	972	32	90	350	348	10	357	M27	2.220	210
450	1.760	1.136	43	50	110	40	110	35	80	210	744	1.436	372	1.066	35	100	350	390	10	399	M30	3.130	315
500	1.952	1.240	45	50	110	45	110	40	110	230	822	1.610	411	1.170	35	110	410	433	10	443	M30	4.300	400
560	2.200	1.404	48	60	140	50	110	40	110	260	902	1.805	451	1.328	38	120	410	392	12	502	M33	5.770	600
630	2.495	1.570	55	65	140	55	110	45	110	300	980	2.024	490	1.480	45	135	470	445	12	575	M36	7.900	860
710	2.790	1.716	62	70	140	65	140	50	110	330	1.088	2.252	544	1.626	45	150	470	498	12	640	M39	10.400	1.210
800	3.135	1.896	70	80	170	70	140	55	110	370	1.202	2.533	601	1.796	50	170	550	559	12	715	M42	13.000	1.700

Posiciones de trabajo Working positions

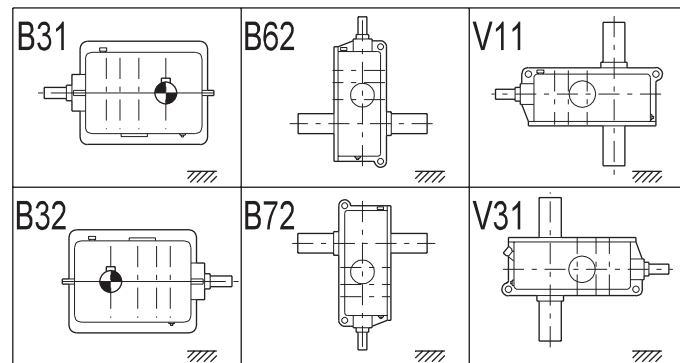

Posición extremos de árboles y Sentidos de giro Shafts position and direction of rotation

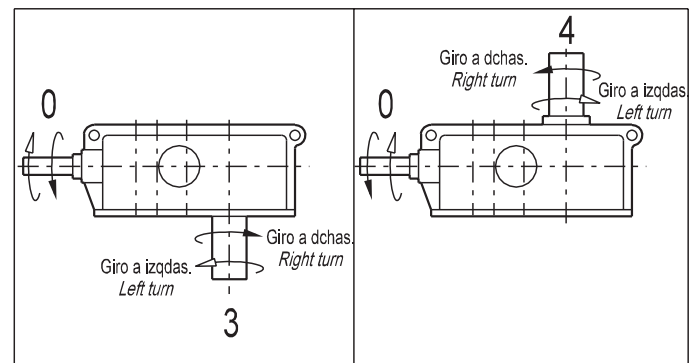

Equipamientos Técnicos Comerciales, S.A. se reserva el derecho de realizar cualquier modificación. / Equipamientos Técnicos Comerciales, S.A. reserves the right to modification.

REDUCTORES TANDEM

ARBOL HUECO - TRANSMISION POR CHAVETA

TANDEM GEAR UNITS

HOLLOW SHAFT - KEY DRIVE

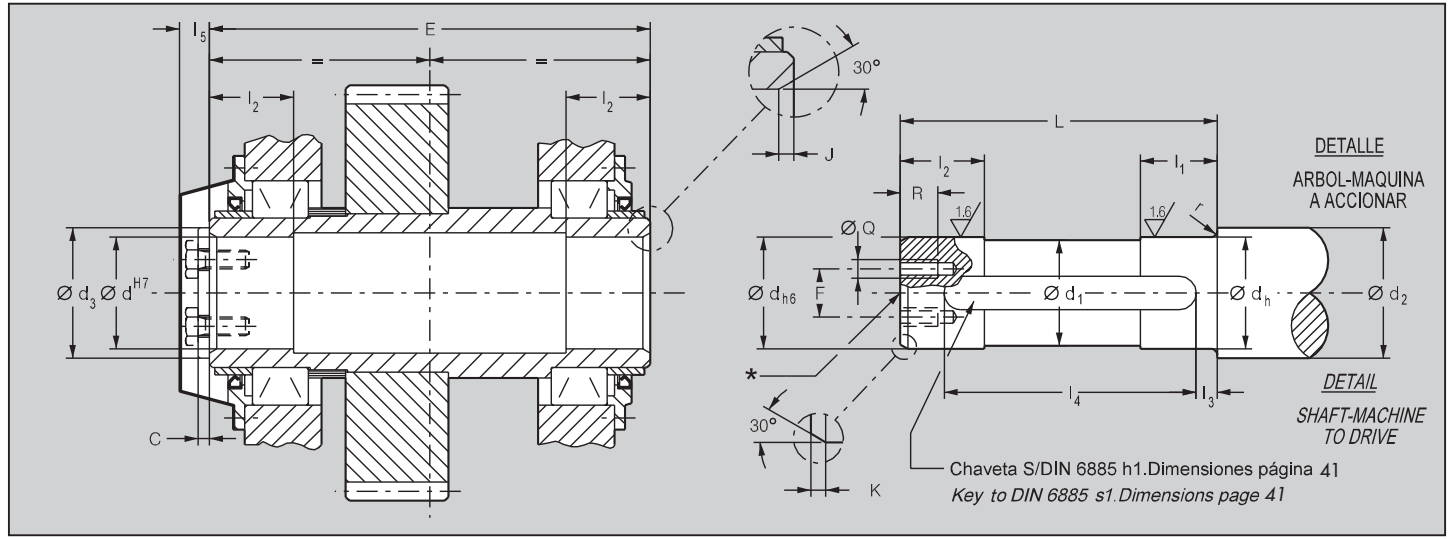

Tamaño Reductor Gear unit size	C	d	d ₁	d ₂ mínimo minimum	d ₃	E	F	J	K	I ₁	I ₂	I ₃	I ₄	I ₅	L	Q 2 a 180° 2 to 180°	r	R
112	7	55	54,5	70	65	246	34	5	3	50	45	30	190	20	244	M8	2,5	20
125	7	60	59,5	75	70	266	37	5	3	55	50	35	200	20	264	M8	2,5	20
140	8	65	64,5	80	80	296	40	5	3	60	55	40	220	25	293	M10	2,5	25
160	10	75	74,5	95	90	340	45	7	4	70	65	45	240	25	337	M10	3,5	25
180	10	85	84,5	105	100	366	55	7	4	75	70	49	270	30	363	M12	3,5	30
200	10	95	94,5	115	115	380	60	7	4	80	75	46	290	30	377	M12	3,5	30
225	12	110	109,5	130	130	420	70	8	5	85	80	51	320	32	417	M16	4	38
250	12	120	119,5	140	140	472	80	8	5	95	90	52	370	32	469	M16	4	38
280	15	130	129,5	150	150	514	85	8	5	105	100	63	390	40	511	M20	4	48

* Punto de centrado con rosca, forma D, s/DIN-332. Dimensiones: pág. 41

* Centering points with thread to D DIN-332. Dimensions: page 41.

ARBOL HUECO - TRANSMISION POR ELEMENTOS DE APRIETE

HOLLOW SHAFT - TIGHTENING ELEMENT DRIVE

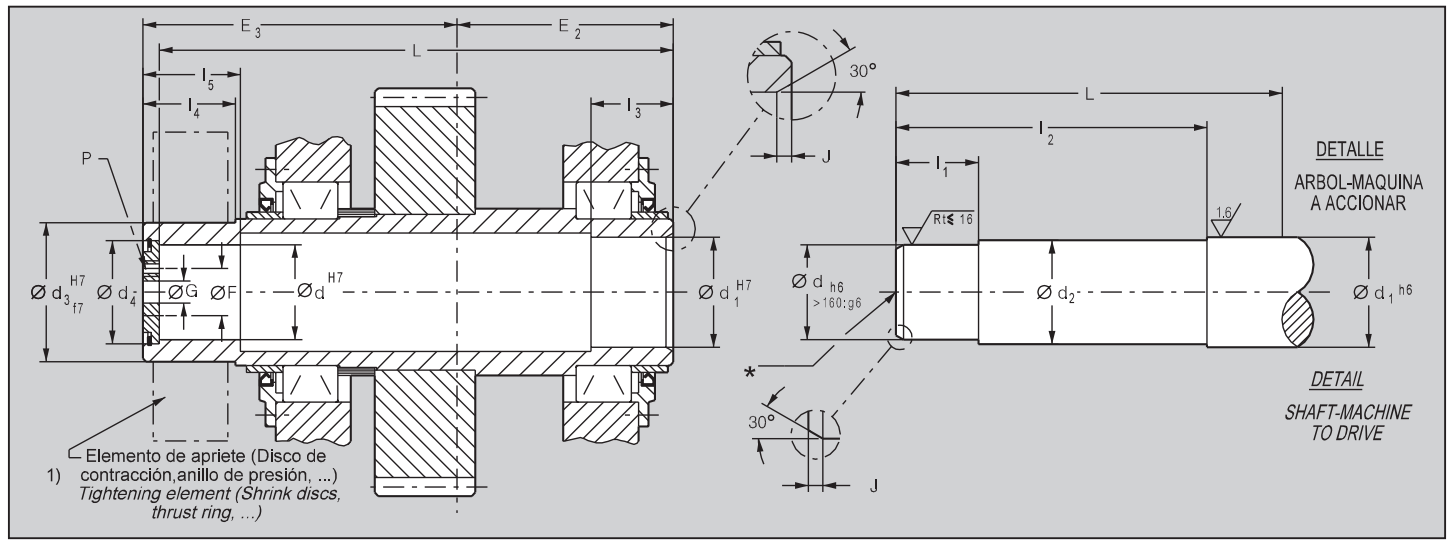

Tamaño Reductor Gear unit size	d	d ₁	d ₂	d ₃	d ₄	E ₂	E ₃	F	G	J	I ₁	I ₂	I ₃	I ₄	I ₅	L	P 3 a 120° 3 to 120°
112	50	55	52	68	54	123	169	30	18	2,5	43	246	26	46	53	277	M6
125	55	60	57	75	60	133	181	35	23	2,5	46	266	28	48	56	299	M6
140	60	65	62	80	65	148	196	39	23	2,5	50	294	30	48	60	329	M6
160	70	80	75	100	80	170	230	46	23	4	60	345	35	60	70	385	M8
180	80	90	85	110	90	183	252	50	23	4	67	372	40	69	80	417	M10
200	90	100	95	125	100	190	263	58	27	4	77	385	45	73	90	435	M12
225	105	115	110	140	115	210	290	62	27	5	85	425	50	80	100	480	M14
250	115	125	120	155	125	236	320	66	27	5	95	476	55	84	110	536	M14
280	140	150	145	185	150	257	367	70	33	5	100	534	60	110	120	599	M16
315	160	170	165	220	170	288	408	80	33	7	121	607	60	120	140	672	M16
355	180	190	185	240	190	317	457	90	33	7	131	675	70	140	150	750	M16
400	200	210	205	260	210	333	483	110	33	7	143	705	80	150	160	792	M16
450	220	230	225	280	230	372	542	110	39	8	158	788	90	170	180	885	M20
500	250	260	255	320	265	411	596	140	39	8	169	862	105	185	195	974	M20
560	280	290	285	360	295	451	662	170	39	8	193	952	120	211	220	1.079	M20
630	340	350	345	420	360	490	740	190	45	10	227	1.033	150	250	260	1.190	M24
710	380	390	385	460	400	544	807	230	45	10	245	1.124	180	263	275	1.311	M24
800	420	430	425	500	440	601	866	270	45	10	245	1.195	220	265	280	1.422	M24

1) E.T.C. puede suministrar los elementos de apriete.

1) E.T.C. can supply the tightening elements.

* Punto de centrado con rosca, forma D, s/DIN-332. Dimensiones: pág. 41.

* Centering points with thread to D DIN 332. Dimensions: page 41.



REDUCTORES TANDEM

PUNTOS DE CENTRADO
CHAVETAS Y CHAVETEROS

TANDEM GEAR UNITS

CENTERING POINTS
KEYS AND KEYWAYS



Puntos de centrado con rosca, forma D, DIN-332 / Centering points with thread to D DIN 332

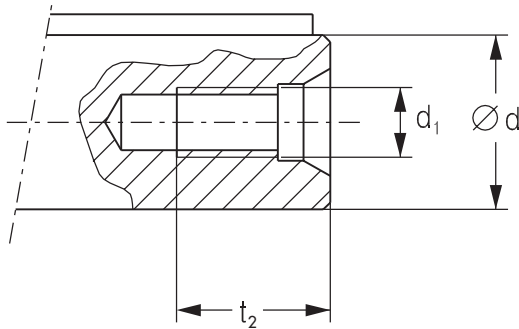

d		d ₁	t ₂ ^{+0,2}
>	≤		
10	13	M4	10
13	16	M5	12,5
16	21	M6	16
21	24	M8	19
24	30	M10	22
30	38	M12	28

d		d ₁	t ₂ ^{+0,2}
>	≤		
38	50	M16	36
50	85	M20	42
85	130	M24	50
130	200	M30	60
200	300	M36	72
300	-	M42	84

Chavetas y chaveteros según DIN - 6885 h. 1 / Keys and keyways to DIN - 6885 s. 1

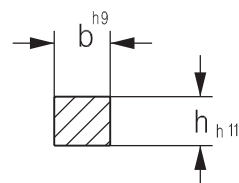
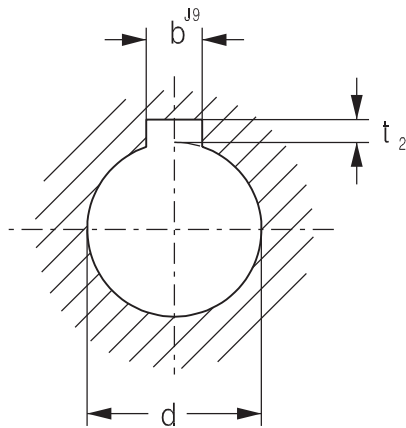
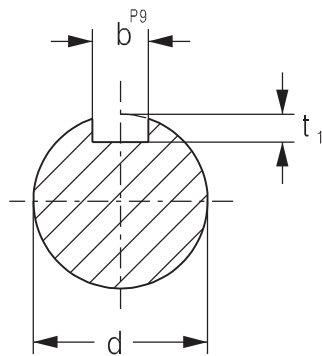

d		b	h	t ₁	Tolerancia Tolerance	t ₂	Tolerancia Tolerance
>	≤						
10	12	4	4	2,5	+0,1	1,8	+0,1
12	17	5	5	3		2,3	
17	22	6	6	3,5		2,8	
22	30	8	7	4	+0,2	3,3	+0,2
30	38	10	8	5		3,3	
38	44	12	8	5		3,3	
44	50	14	9	5,5		3,8	
50	58	16	10	6		4,3	
58	65	18	11	7		4,4	
65	75	20	12	7,5	4,9	+0,3	+0,3
75	85	22	14	9	5,4		
85	95	25	14	9	5,4		
95	110	28	16	10	+0,3	6,4	+0,3
110	130	32	18	11		7,4	
130	150	36	20	12		8,4	
150	170	40	22	13		9,4	
170	200	45	25	15		10,4	
200	230	50	28	17		11,4	
230	260	56	32	20		12,4	
260	290	63	32	20		12,4	
290	330	70	36	22		14,4	
330	380	80	40	25		15,4	
380	440	90	45	28	17,4		
440	500	100	50	31	19,4		

Equipamientos Técnicos Comerciales, S.A. se reserva el derecho de realizar cualquier modificación. / Equipamientos Técnicos Comerciales, S.A. reserves the right to modification.

REDUCTORES TANDEM

SÍMBOLOS Y UNIDADES DE MEDIDA

TANDEM GEAR UNITS

SYMBOLS AND UNITS OF MEASURE



Símbolos en orden alfabético con las correspondientes unidades de medida utilizadas en el catálogo y fórmulas.

Symbols in alphabetical order, with relevant units of measure used in the catalogue and formulas

Símbolo Symbol	Definición Definition	En el catálogo In the catalogue	Unidades de medida en las fórmulas Units of measures in the formulas		Notas Notes
			Sistema técnico Technical system	Sistema internacional International system	
	Dimensiones, cotas / Dimensions	mm	—		
a	Aceleración / Acceleration	—	m/s ²		
d	Diámetro / Diameter	—	m		
ED	Período de conexión por hora / Rel. operating time per hour	%			
f	Frecuencia / Frequency	—	Hz		
f _a	Factor de aplicación total / Total application factor	—			
f _t	Factor térmico / Thermal factor				
f ₁	Factor aplicación según grupos de carga / Application factor accor. to load classification				
f ₂	Factor aplicación según arranques-hora / Application factor accor. to starts/hour				
f ₃	Factor aplicación según horas de vida / Application factor accor. to lifetime				
F	Fuerza / Force	—	kgf	N	1 kgf = 9,81 N = 0,981 daN
F _r	Carga radial / Radial load	—	—		
F _a	Carga axial / Axial load	—	—		
g	Aceleración de gravedad / Acceleration of gravity	—	m/s ²		Valor normal / Normal Value 9,81 m/s ²
G	Peso (fuerza) / Weight (force)	—	kgf	N	
Gd ²	Momento dinámico / Dynamic moment	—	kgf m ²	—	
i _n	Relación de transmisión reductora / Gear unit transmission ratio				$i = \frac{n_1}{n_2}$
I	Corriente eléctrica / Electric current	—	A		
J	Momento de inercia / Moment of inertia	—	—	kg m ²	
l _h	Duración rodamientos / Bearing life	—	—		
m	Masa / Mass	—	kgf s ² /m	kg	
M	Par / Torque	—	kgf m	N m	1 kgf m = 9,81 N m = 0,981 daN m
n ₁	Velocidad rápida / Fast speed	r.p.m.	rev/min	—	1 rev/min = min ⁻¹ = 0,105 rad/s
n ₂	Velocidad lenta / slow speed	r.p.m.	rev/min	—	1 rev/min = min ⁻¹ = 0,105 rad/s
P _{Gn}	Potencia límite térmica necesaria / Neccesary maximum thermal power	Kw	Cv / Hp	w	1 Cv ≈ 736 w = 0,736 Kw / 1 Hp = 736 w = 0,736 Kw
P _{G1}	Potencia límite térmica sin refrigeración adicional / Maximum thermal power without additional cooling	Kw	Cv / Hp	w	1 Cv ≈ 736 w = 0,736 Kw / 1 Hp = 736 w = 0,736 Kw
P _{G2}	Potencia límite térmica con refrigeración por ventilador / Maximum thermal power with fan cooling	Kw	Cv / Hp	w	1 Cv ≈ 736 w = 0,736 Kw / 1 Hp = 736 w = 0,736 Kw
P _{G3}	Potencia límite térmica con refrigeración por serpentín / Maximum thermal power with coil cooling	Kw	Cv / Hp	w	1 Cv ≈ 736 w = 0,736 Kw / 1 Hp = 736 w = 0,736 Kw
P _{G4}	Potencia límite térmica con refrigeración por ventilador y serpentín / Maximum thermal power with fan and coil cooling	Kw	Cv / Hp	w	1 Cv ≈ 736 w = 0,736 Kw / 1 Hp = 736 w = 0,736 Kw
P _N	Potencia nominal reductor según tablas de potencia / Gear unit nominal power according to tables of power	Kw	Cv / Hp	w	1 Cv ≈ 736 w = 0,736 Kw / 1 Hp = 736 w = 0,736 Kw
P ₁	Potencia motriz o instalada (del motor, turbina, etc) / Driving power (motor, turbine, etc.)	Kw	Cv / Hp	w	1 Cv = 736 w = 0,736 Kw / 1 Hp = 736 w = 0,736 Kw
P _a	Potencia absorbida por la máquina accionada / Absorbed power by the driven machine	Kw	Cv / Hp	w	1 Cv = 736 w = 0,736 Kw / 1 Hp = 736 w = 0,736 Kw
P _{Nh}	Potencia nominal necesaria / Neccesary nominal power	Kw	Cv / Hp	w	1 Cv = 736 w = 0,736 Kw / 1 Hp = 736 w = 0,736 Kw
r	Radio / Radius	—	m		
T	Temperatura Celsius / Celsius Temperature	°C	—		
t	Tiempo / Time	s min h d	s		1 min = 60 s 1 h = 60 min = 3600 s 1 d = 24 h = 86400 s
V	Voltaje / Voltage	—	V		
v	Velocidad / Speed	—	m/s		
W	Trabajo, Energía / Work, energy	—	kgf m	J	
z	Frecuencia de arranque / Frequency of starting	arranques/h · starts/h	—		
α	Aceleración angular / Angular acceleration	—	rad/s ²		
η	Rendimiento / Efficiency				
φ	Angulo plano / Plane angle	°	rad		1 revolución = 2 π rad / 1 revolution = 2 π rad $1^\circ = \frac{\pi}{180} \text{ rad}$
ω	Velocidad angular / Angular speed	—	—	rad/s	1 rad/s = 9,55 rev/min

Equipamientos Técnicos Comerciales, S.A. se reserva el derecho de realizar cualquier modificación. / Equipamientos Técnicos Comerciales, S.A. reserves the right to modification.

Principales fórmulas relacionadas con las transmisiones mecánicas según el Sistema Técnico y el sistema internacional de Unidades (SI)

Main formulas related to the mechanical transmissions according to the Technical System and the International Unit System. (SI)

DENOMINACION	Con Sistema Técnico With Technical System	Con Sistema Internacional With International System	DENOMINATION
Tiempo de arranque o de detención, en función de una aceleración o desaceleración, de un par de arranque o de frenado.	$t = \frac{Gd^2 \cdot n}{375 \cdot M} \text{ [s]}$	$t = \frac{J \cdot \omega}{M} \text{ [s]}$	Starting or stopping time, as a function of an acceleration or deceleration, of a starting or braking torque.
Velocidad en el movimiento rotativo.	$v = \frac{\pi \cdot d \cdot n}{60} = \frac{d \cdot n}{19,1} \text{ [m/s]}$	$v = \omega \cdot r \text{ [m/s]}$	Speed in rotary motion.
Velocidad angular.	$n = \frac{60 \cdot v}{\pi \cdot d} = \frac{19,1 \cdot v}{d} \text{ [R.p.m.]}$	$\omega = \frac{v}{r} \text{ [rad/s]}$	Angular speed.
Aceleración o desaceleración en función de un tiempo de arranque o de detención.	$\alpha = \frac{v}{t} \text{ [m/s}^2\text{]}$	$\alpha = \frac{\omega}{t} \text{ [rad/s}^2\text{]}$	Acceleration or deceleration, as a function of a starting or stopping time.
Aceleración o desaceleración angular en función de un tiempo de arranque o de detención, de un par de arranque o de frenado.	$\alpha = \frac{m}{9,55 \cdot t} \text{ [rad/s}^2\text{]}$ $\alpha = \frac{39,2 \cdot M}{Gd^2} \text{ [rad/s}^2\text{]}$	$\alpha = \frac{\omega}{t} \text{ [rad/s}^2\text{]}$ $\alpha = \frac{M}{J} \text{ [rad/s}^2\text{]}$	Angular acceleration or deceleration, as a function of a starting or stopping time, of a starting or braking torque.
Espacio de arranque o de detención, en función de una aceleración o desaceleración, de una velocidad final o inicial.	$s = \frac{\alpha \cdot t^2}{2} \text{ [m]}$ $s = \frac{v \cdot t}{2} \text{ [m]}$	$s = \frac{\alpha \cdot t^2}{2} \text{ [m]}$ $s = \frac{v \cdot t}{2} \text{ [m]}$	Starting or stopping distance, as a function of an acceleration or deceleration, of a final or initial speed.
Angulo de arranque o de detención, en función de una aceleración o desaceleración angular, de una velocidad angular final o inicial.	$\varphi = \frac{n \cdot t}{19,1} \text{ [rad]}$	$\varphi = \frac{\omega \cdot t}{2} \text{ [rad]}$	Starting or stopping angle, as a function of an acceleration or deceleration, of a final or initial speed.
Masa.	$m = \frac{G}{g} \left[\frac{\text{kgf} \cdot \text{s}^2}{\text{m}} \right]$	m es la unidad de masa [kg] m is the unit of mass [kg]	Mass.
Peso (fuerza peso).	G es la unidad de peso (fuerza) [kgf] G is the unit of weight (force) [kgf]	$G = m \cdot g \text{ [N]}$	Weight (force).
Fuerza en el movimiento de traslación vertical (elevación), horizontal, inclinado (μ = coeficiente de rozamiento; φ = ángulo de inclinación).	$F = G \text{ [kgf]}$ $F = \mu \cdot G \text{ [kgf]}$ $F = G (\mu \cdot \cos \varphi + \text{sen } \varphi) \text{ [kgf]}$	$F = m \cdot g \text{ [N]}$ $F = \mu \cdot m \cdot g \text{ [N]}$ $F = m \cdot g (\mu \cdot \cos \varphi + \text{sen } \varphi) \text{ [N]}$	Force in motion of vertical (lifting), horizontal and inclined translation (μ = coefficient of friction; φ = angle of inclination).
Momento dinámico Gd^2 , momento de inercia J debido a un movimiento de traslación (numéricamente $J = \frac{Gd^2}{4}$).	$Gd^2 = \frac{365 \cdot G \cdot v^2}{n^2} \text{ [kgf m}^2\text{]}$	$J = \frac{m \cdot v^2}{\omega^2} \text{ [kg m}^2\text{]}$	Dynamic moment Gd^2 , moment of inertia J due to a motion of translation (numerically $J = \frac{Gd^2}{4}$).
Par en función de una fuerza, de un momento dinámico o de inercia, de una potencia.	$M = \frac{F \cdot d}{2} \text{ [kgf m]}$ $M = \frac{Gd^2 \cdot d}{375 \cdot t} \text{ [kgf m]}$ $M = \frac{716 \cdot P}{n} \text{ [kgf m]}$	$M = F \cdot r \text{ [N m]}$ $M = \frac{J \cdot \omega}{t} \text{ [N m]}$ $M = \frac{P}{\omega} \text{ [N m]}$	Torque as a function of a force, of a dynamic moment or a moment of inertia and of a power.
Trabajo, energía en el movimiento de traslación y de rotación.	$W = \frac{G \cdot v^2}{19,6} \text{ [kgf m]}$ $W = \frac{Gd^2 \cdot n^2}{7160} \text{ [kgf m]}$	$W = \frac{m \cdot v^2}{2} \text{ [J]}$ $W = \frac{J \cdot \omega^2}{2} \text{ [J]}$	Work, energy in motion of translation and in rotary motion.
Potencia en el movimiento de traslación y de rotación.	$P = \frac{F \cdot v}{75} \text{ [CV]}$ $P = \frac{M \cdot n}{716} \text{ [CV]}$	$P = F \cdot v \text{ [W]}$ $P = M \cdot \omega \text{ [W]}$	Power in motion of translation and in rotary motion.
Potencia obtenida en el árbol de un motor monofásico ($\cos \varphi$ = factor de potencia).	$P = \frac{U \cdot I \cdot \eta \cdot \cos \varphi}{736} \text{ [CV]}$	$P = U \cdot I \cdot \eta \cdot \cos \varphi \text{ [W]}$	Power available at the shaft of a single-phase motor ($\cos \varphi$ = power factor).
Potencia obtenida en el árbol de un motor trifásico.	$P = \frac{U \cdot I \cdot \eta \cdot \cos \varphi}{425} \text{ [CV]}$	$P = 1,73 \cdot U \cdot I \cdot \eta \cdot \cos \varphi \text{ [W]}$	Power available at the shaft of a three-phase motor.

Nota: La aceleración o la desaceleración deben ser consideradas constantes; los movimientos de traslación y de rotación deben ser considerados, respectivamente, rectilíneo y circular.

Note: Acceleration or deceleration are understood constant; motion of translation and rotary motion are understood rectilinear and circular respectively.



DEPARTAMENTO DE PROYECTOS
PROJETS DEPARTMENT



FICHA DE DATOS / DATA CARD

REQUISITOS PARA EL DISEÑO / REQUIREMENT FOR THE DESIGN
Procedimiento 4.01 (MANPRO41) / Procedure 4.01 (MANPRO41)



EQUIPAMIENTOS
TECNICOS
COMERCIALES

San Martín, 11 - ZAMUDIO - VIZCAYA (SPAIN)
TELF.: 94 452 09 61 • FAX: 94 452 07 03
APARTADO 1.066 - 48080 BILBAO

DATOS COMERCIALES / COMMERCIAL DATA

FIRMA: _____ CODIGO: _____
COMPANY: _____ CODE: _____

DIRECCION: _____ PROVINCIA: _____ PAIS: _____
ADDRESS: _____ PROVINCE: _____ COUNTRY: _____

TELEFONO: _____ TELEFAX: _____ CONSULTADO POR: _____
TELEPHONE: _____ TELEFAX: _____ REQUESTED BY: _____

DESTINO PROYECTO: _____
UTILITY OF THE PROJECT: _____

N.º DE CONSULTA: _____ OFERTA N.º _____ FECHA: _____
NUMBER OF REQUEST: _____ OFFER NUM.: _____ DATE: _____

DATOS TECNICOS / TECHNICAL DATA

VALORES POR DEFECTO DEFAULT VALUES

A MAQUINA MOTRIZ / DRIVING MACHINE	A1 TIPO DE MOTOR KIND OF MOTOR	_____	A2 POTENCIA NOMINAL (KW) NOMINAL POWER	_____	A1 Eléctrico jaula / Electric squirrel cage A3 1.500 r.p.m. A4 2,5
	A3 VELOCIDAD NOMINAL (r.p.m.) NOMINAL SPEED	_____	A4 PAR MAX. / NOMINAL (M) MAX./NOMINAL TORQUE	_____	
	A5 DATOS COMPLEMENTARIOS COMPLEMENTARY DATA	_____			
	OBSERVACIONES COMMENTS	_____			
B MAQUINA ACCIONADA / DRIVEN MACHINE	B1 TIPO DE MAQUINA KIND OF MACHINE	_____	B2 POTENCIA EFECTIVA (KW) ABSORBED POWER	_____	B2 80 % motor B4 1,5 B5 8 / 24 B6 10 B7 100 % ED
	B3 VELOCIDAD NOMINAL (r.p.m.) NOMINAL SPEED	_____	B4 FACTOR APLICACION (fa) APPLICATION FACTOR	_____	
	B5 FUNCIONAMIENTO DIARIO SERVICE HOURS	_____	B6 ARRANQUES / HORA STARTS / HOURS	_____	
	B7 CONEXION % ED RUNNING TIME % ED	_____	_____		
OBSERVACIONES COMMENTS	_____				
C CONDICIONES DE TRABAJO / WORKING CONDITIONS	C1 TIPO DE AMBIENTE KIND OF ENVIRONMENT	_____			C1 Limpio, cubierto / clean, covered C2 + 30 grados / Degrees C3 + 5 grados / Degrees
	C2 TEMPERATURA MAXIMA (C°) MAXIMUM TEMPERATURE	_____	C3 TEMPERATURA MINIMA (C°) MINIMUM TEMPERATURE	_____	
	OBSERVACIONES COMMENTS	_____			
D CARACTERISTICAS DEL MECANISMO / CHARACTERISTICS OF THE MECHANISM	D1 TIPO DE MECANISMO KIND OF MECHANISM	_____			D1 TANDEM D2 Patas / Feet D5 1.500 r.p.m. D6 . . . (±)3% D7 80 grd. máx. / 80 degrees max.
	D2 EJECUCION EXECUTION	_____			
	D3 TAMAÑO SIZE	_____	D4 POTENCIA / PAR NOMINAL (p) POWER / NOMINAL TORQUE	_____	
	D5 VELOCIDAD NOMINAL (r.p.m.) NOMINAL SPEED	_____	D6 REDUCCION NOMINAL (i) NOMINAL RATIO	_____	
	D7 Ta. FUNC. MAX./P.L.T. MAX. FUNC. TEMP./M.T.P.	_____			
OBSERVACIONES COMMENTS	_____				
E ARBOL RAPIDO DEL MECANISMO / FAST SHAFT	E1 TIPO DE ARBOL KIND OF SHAFT	_____	E2 TIPO DE UNION KIND OF JOINT	_____	E1 Macizo / Solid E2 Elástica / Elastic E3 0 N m E4 0 N m
	E3 CARGA RADIAL (fr) RADIAL LOAD	_____	E4 CARGA AXIAL (fa) AXIAL LOAD	_____	
	OBSERVACIONES COMMENTS				

F ARBOL LENTO DEL MECANISMO / SLOW SHAFT	F1 TIPO DE ARBOL KIND OF SHAFT	_____	F2 TIPO DE UNION KIND OF JOINT	_____	F1 Macizo / Solid F2 Elástica / Elastic F3 0 N m F4 0 N m
	F3 CARGA RADIAL (fr) RADIAL LOAD	_____	F4 CARGA AXIAL (fa) AXIAL LOAD	_____	
	OBSERVACIONES COMMENTS				

OTROS DATOS / OTHER DATA:

Dibujen un esquema de la posición en hoja aparte. / Draw a sketching drawing of the position on another sheet.

Equipamientos Técnicos Comerciales, S.A. se reserva el derecho de realizar cualquier modificación. / Equipamientos Técnicos Comerciales, S.A. reserves the right to modification.

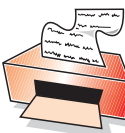
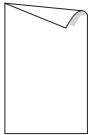
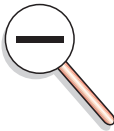
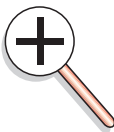
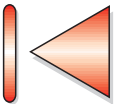

REDUCTORES Y
MOTO-REDUCTORES
DE VELOCIDAD

GEAR UNITS
AND MOTOR GEAR UNITS
OF SPEED

TIPOS - TYPES **SINFIN**

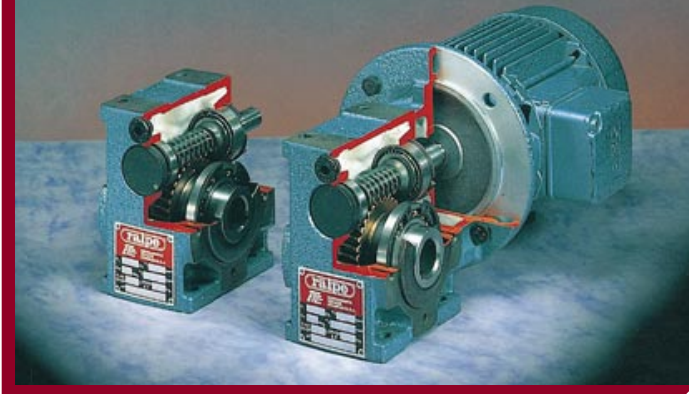

REDUCTORES
DE VELOCIDAD
DE ARBOL HUECO

HOLLOW SHAFT
GEAR UNITS

TIPOS - TYPES **CTE-CT**



REDUCTORES Y
MOTO-REDUCTORES
DE VELOCIDAD

GEAR UNITS
AND MOTOR GEAR UNITS
OF SPEED

TIPOS - TYPES **T y D**



**PROGRAMA DE FABRICACION Y COMERCIALIZACION
PRODUCTION AND COMMERCIAL PROGRAM**

MECANISMOS ESTANDAR

REDUCTORES Y MOTOREDUCTORES DE VELOCIDAD.
REDUCTORES DE VELOCIDAD DE ARBOL HUECO.
REDUCTORES DE VELOCIDAD TIPO "TANDEM".
VARIADORES DE VELOCIDAD DE FRICCIÓN Y POLEAS.
EMBRAGUES Y ACOPLADORES HIDRODINAMICOS.
EMBRAGUES Y FRENOS ELECTROMAGNETICOS.

STANDARD MECHANISMS

GEAR UNITS AND MOTOR GEAR UNITS.
HOLLOW SHAFT GEAR UNITS.
TANDEM GEAR UNITS.
FRICTION AND PULLEYS SPEED VARIATORS.
HYDRODINAMIC CLUTCHES AND COUPLINGS.
ELECTROMAGNETIC CLUTCHES AND BRAKES.

MECANISMOS ESPECIALES

REDUCTORES PARA MEZCLADORAS DE GOMA Y CALANDRAS.
REDUCTORES "DUO" Y "TRIO" PARA TRENES DE LAMINACION.
REDUCTORES ENROLLADORES Y DESENROLLADORES CON
CAMBIO DE VELOCIDADES PARA TRENES DE LAMINACION.
REDUCTORES DE ARBOL HUECO PARA EL ACCIONAMIENTO
Y TENSADO DE GRANDES CINTAS TRANSPORTADORAS.
MOTO-RODILLOS PARA EL ACCIONAMIENTO DE COLADAS CONTINUAS.

SPECIAL MECHANISMS

GEAR UNITS FOR RUBBER MIXER AND CALENDERS.
"DUO" AND "TRIO" GEAR UNITS FOR ROLLING MILLS.
COILER AND UNCOILER GEAR UNITS WITH GEAR SHIFT FOR ROLLING MILLS.
HOLLOW SHAFT GEAR UNITS FOR DRIVING AND TIGHTENING BIG BELT CONVEYORS.
MOTO-ROLLERS FOR DRIVING CONTINUOUS SELTS.